



FK DN 40÷400
PVC-U

Butterfly valve

FK DN 40÷400

BUTTERFLY VALVE

- Interchangeable disk in PVC-U with through shaft, available in different thermoplastic materials: PP-H, PVC-C, ABS, PVDF
- Overall dimensions of the valve in accordance with standard ISO 5752 (DN 40÷200 Medium Series 25, DN 250÷ 300 Long Series 16) and DIN 3202 K2 and ISO 5752 (DN 65÷200 K2, DN 250÷300 K3)
- Can also be installed as an end line valve, bottom discharge valve or tank dump valve
- **Special Lug version** PN 10 fully drilled to DIN 2501 or ANSI B16.5 cl.150 **with molded-in AISI 316 stainless steel threaded inserts**
- **Valve material compatibility** (PVC-U + EPDM) with water conveyance, drinking water and other food substances according to **current regulations**
- Possibility of installing a manual reducer or pneumatic and/or electric actuators by applying an ISO standard drilling PP-GR flanges. DN 40 ÷ 200 valve fitted with plate with rack in PP-GR. For actuated versions with flange drilled according to ISO 5211 F05, F07, F10. DN 250÷400 valve, fitted with one-piece top flange in high mechanical strength PP-GR with mounting flange for internal components drilled according to standard ISO 5211 F10 (excluding DN 350÷400), F12, F14.

Technical specifications	
Construction	Bi-directional centric butterfly valve
Size range	DN 40÷400
Nominal pressure	Wafer version DN 40÷50: PN 16 with water at 20° C DN 65÷250: PN 10 with water at 20° C DN 300: PN 8 with water at 20° C DN 350: PN 7 with water at 20° C DN 400: PN 6 with water at 20° C Lug version DN 65÷200: PN 10 with water at 20° C DN 250÷300: PN 6 with water at 20° C
Temperature range	0 °C ÷ 60 °C
Coupling standards	Flanging system: EN ISO 1452, EN ISO 15493, DIN 2501, ISO 7005-1, EN 1092-1, ASTM B16.5 Cl.150
Reference standards	Construction criteria: EN ISO 16136, EN ISO 1452, EN ISO 15493 Test methods and requirements: ISO 9393 Actuator couplings: ISO 5211
Valve material	Body: PP-GR Disk: PVC-U Stem: STAINLESS steel AISI 316
Seal material	Liner: EPDM, FPM. On request NBR
Control options	Hand lever operated (DN 40÷200); Gearbox, pneumatic actuator, electric actuator

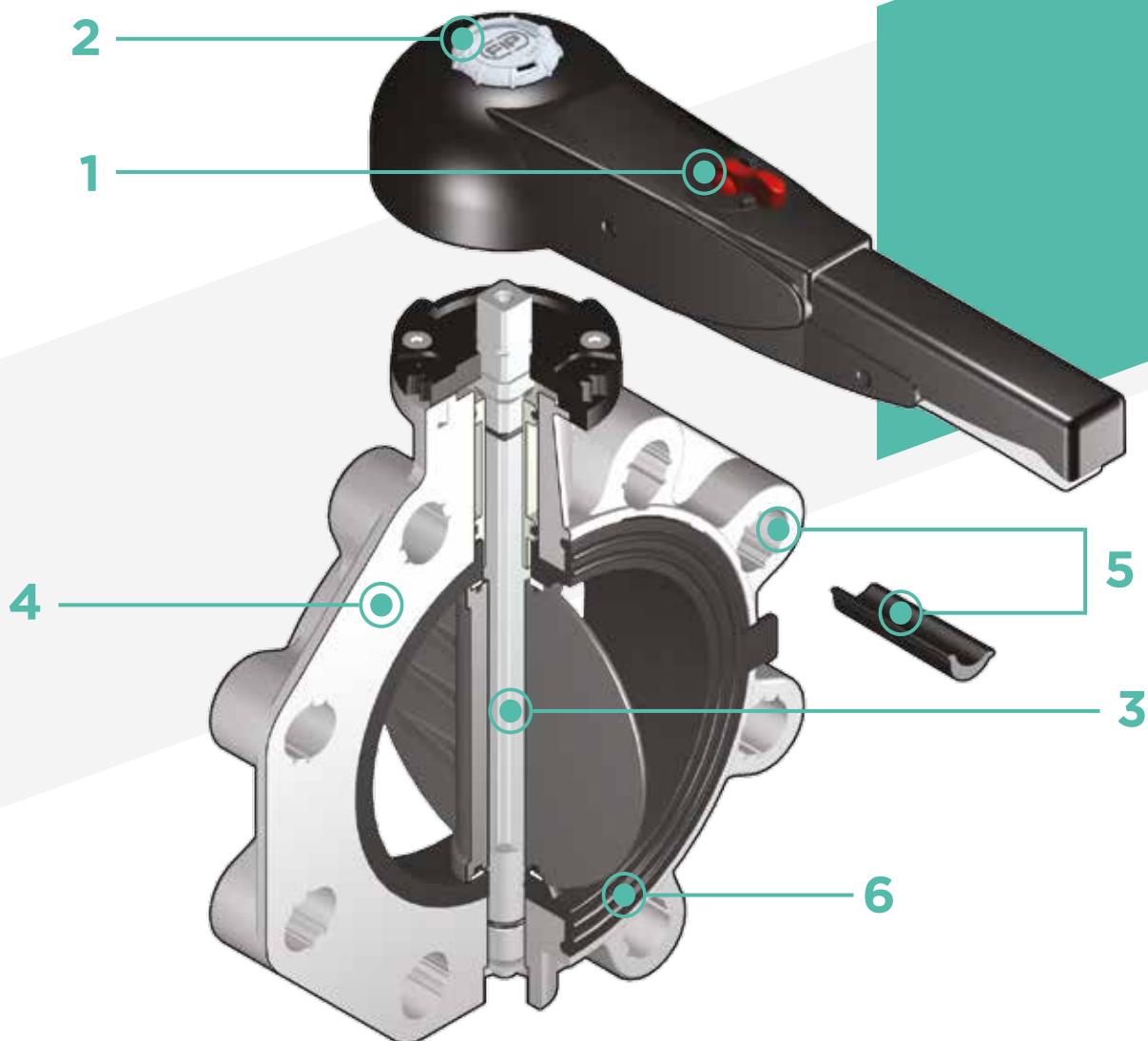

1 Ergonomic handle in HIPVC equipped with **locking and unlocking device, release, quick operation and graduated adjustment** in 10 intermediate positions (DN 40÷200). The operating range, starting from the first few degrees of valve opening, also guarantees extremely low pressure drops.

2 Customisable Labelling System: integrated module in the handle, made of a transparent protection plug and a customisable tag holder using the LSE set (available as an accessory). The **customisation** lets you **identify the valve on the system** according to specific needs.

3 STAINLESS steel square section stem completely isolated from the fluid complying with standard ISO 5211:
 DN 40÷65: 11 mm
 DN 80÷100: 14 mm
 DN 125÷150: 17 mm
 DN 200: 22 mm
 DN 250÷400: 27 mm

4 Body in polypropylene based compound reinforced with **fibreglass (PP-GR) resistant to UV rays** and characterised by **high mechanical strength**.

5 Drilling pattern using **oval slots** that allow coupling to flanges according to numerous

international standards. The special **self-centring inserts in ABS** supplied for DN 40÷200 guarantee the **correct axial alignment** of the valve during installation.

For DN 250÷400 valves, the drilling pattern for the self-centring system is of the traditional type according to DIN and ANSI standards.

6 Interchangeable liner with the dual function of forming a hydraulic seal and isolating the body from the fluid.

TECHNICAL DATA

PRESSURE VARIATION ACCORDING TO TEMPERATURE

For water and harmless fluids to which the material is classified as CHEMICALLY RESISTANT. In other cases, a reduction of the nominal PN pressure is required (25 years with safety factor).

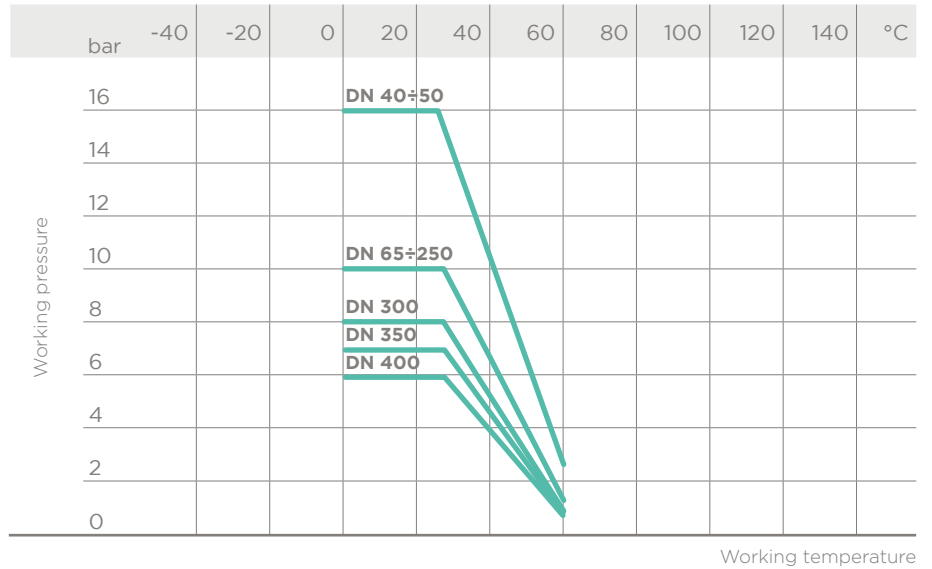

PRESSURE DROP GRAPH

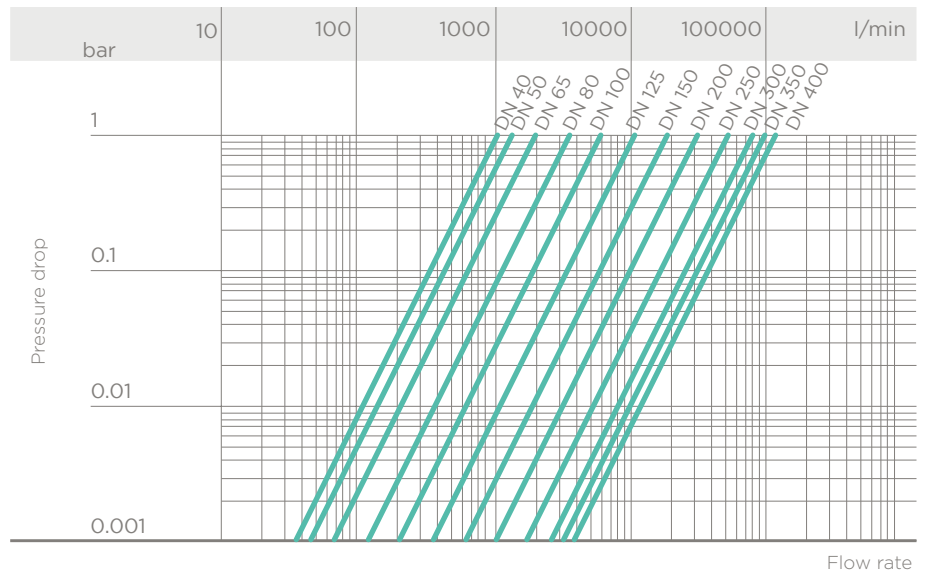

K_v100 FLOW COEFFICIENT

The K_v100 flow coefficient is the Q flow of litres per minute of water at a temperature of 20°C that will generate Δp= 1 bar pressure drop at a certain valve position.

The K_v100 values shown in the table are calculated with the valve completely open.

DN	40	50	65	80	100	125	150	200	250	300	350	400
K _v 100 l/min	1000	1285	1700	3550	5900	9850	18700	30500	53200	81600	94100	124900

RELATIVE FLOW COEFFICIENT GRAPH

The relative flow coefficient is the flow rate through the valve as a function of the degree of valve opening.

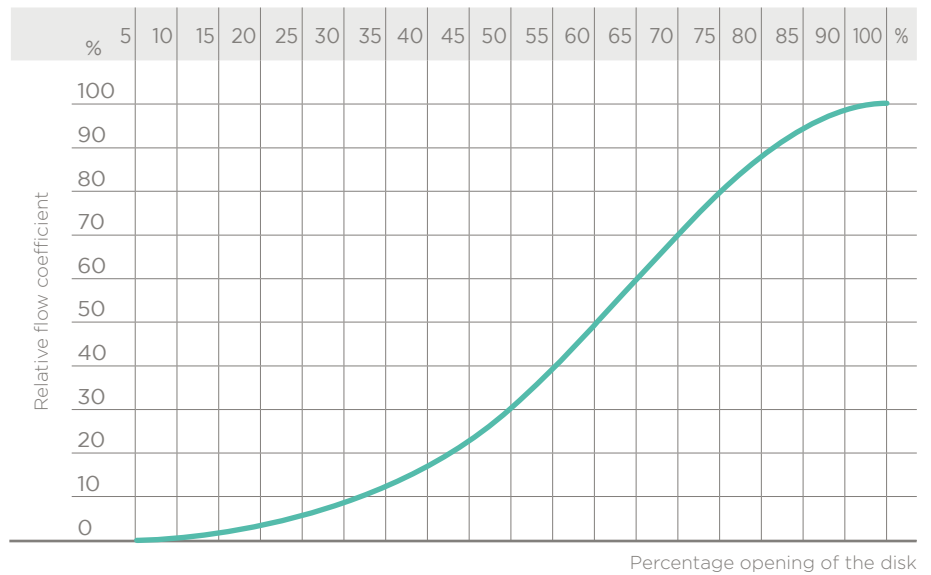

OPERATING TORQUE AT MAXIMUM WORKING PRESSURE

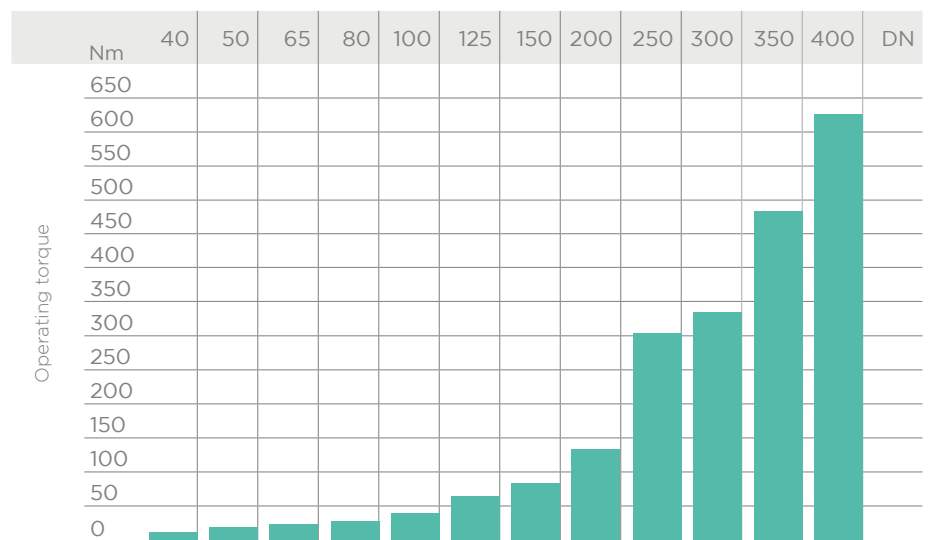

The information in this leaflet is provided in good faith. No liability will be accepted concerning technical data that is not directly covered by recognised international standards. FIP reserves the right to carry out any modification. Products must be installed and maintained by qualified personnel.

DIMENSIONS

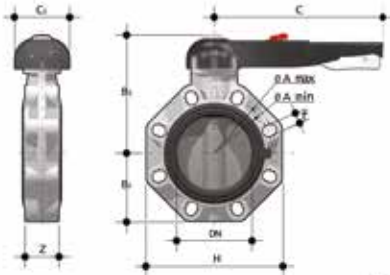

FKOV/LM

Hand operated Butterfly valve

d	DN	PN	A min	A max	B ₂	B ₃	C	C ₁	H	U	Z	g	EPDM Code	FPM Code
50	40	16	99	109	60	137	175	100	132	4	33	1000	FKOVLM050E	FKOVLM050F
63	50	16	115	125.5	70	143	175	100	147	4	43	1180	FKOVLM063E	FKOVLM063F
75	65	10	128	144	80	164	175	110	165	4	46	1570	FKOVLM075E	FKOVLM075F
90	80	10	145	160	93	178	272	110	185	8	49	2020	FKOVLM090E	FKOVLM090F
110	100	10	165	190	107	192	272	110	211	8	56	2370	FKOVLM110E	FKOVLM110F
140	125	10	204	215	120	212	330	110	240	8	64	3300	FKOVLM140E	FKOVLM140F
160	150	10	230	242	134	225	330	110	268	8	70	4100	FKOVLM160E	FKOVLM160F
225	200	10	280	298	161	272	420	122	323	8	71	7050	FKOVLM225E	FKOVLM225F

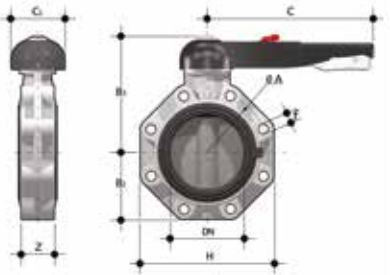

FKOV/LM LUG ISO-DIN

Hand operated Butterfly valve, version Lug ISO-DIN

d	DN	PN	øA	B ₂	B ₃	C	C ₁	f	H	U	Z	g	EPDM Code	FPM Code
75	65	10	145	80	164	175	110	M16	165	4	46	1870	FKOLVLM075E	FKOLVLM075F
90	80	10	160	93	178	175	110	M16	185	8	49	2670	FKOLVLM090E	FKOLVLM090F
110	100	10	180	107	192	272	110	M16	211	8	56	3020	FKOLVLM110E	FKOLVLM110F
140	125	10	210	120	212	330	110	M16	240	8	64	4700	FKOLVLM140E	FKOLVLM140F
160	150	10	240	134	225	330	110	M20	268	8	70	5450	FKOLVLM160E	FKOLVLM160F
225	200	10	295	161	272	420	122	M20	323	8	71	8350	FKOLVLM225E	FKOLVLM225F

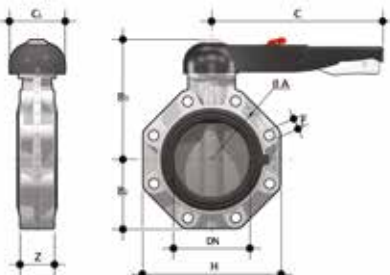

FKOV/LM LUG ANSI

Hand operated Butterfly valve, version Lug ANSI

d	DN	PN	øA	B ₂	B ₃	C	C ₁	f	H	U	Z	g	EPDM Code	FPM Code
2" 1/2	65	10	139.7	80	164	175	110	5/8"	165	4	46	1870	FKOALVLM212E	FKOALVLM212F
3"	80	10	152.4	93	178	175	110	5/8"	185	8	49	2670	FKOALVLM300E	FKOALVLM300F
4"	100	10	190.5	107	192	272	110	5/8"	211	8	56	3020	FKOALVLM400E	FKOALVLM400F
5"	125	10	215.9	120	212	330	110	3/4"	240	8	64	4700	FKOALVLM500E	FKOALVLM500F
6"	150	10	241.3	134	225	330	110	3/4"	268	8	70	5450	FKOALVLM600E	FKOALVLM600F
8"	200	10	298.4	161	272	420	122	3/4"	323	8	71	8350	FKOALVLM800E	FKOALVLM800F

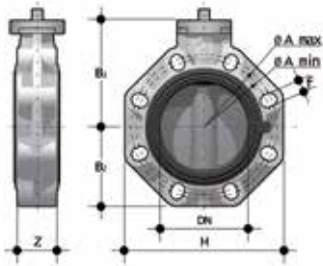

FKOV/FM

Butterfly valve with bare shaft

d	DN	PN	A min	A max	øA	B ₁	B ₂	f	H	U	Z	g	EPDM Code	FPM Code
50	40	16	99	109	-	106	60	19	132	4	33	574	FKOVFM050E	FKOVFM050F
63	50	16	115	125.5	-	112	70	19	147	4	43	754	FKOVFM063E	FKOVFM063F
75	65	10	128	144	-	119	80	19	165	4	46	1000	FKOVFM075E	FKOVFM075F
90	80	10	145	160	-	133	93	19	185	8	49	1400	FKOVFM090E	FKOVFM090F
110	100	10	165	190	-	147	107	19	211	8	56	1750	FKOVFM110E	FKOVFM110F
*125	125	10	204	215	-	167	120	23	240	8	64	2550	FKOVFM140E	FKOVFM140F
140	125	10	204	215	-	167	120	23	240	8	64	2550	FKOVFM140E	FKOVFM140F
160	150	10	230	242	-	180	134	23	268	8	70	3300	FKOVFM160E	FKOVFM160F
**200	200	10	280	298	-	227	161	23	323	8	71	6000	FKOVFM225E	FKOVFM225F
225	200	10	280	298	-	227	161	23	323	8	71	6000	FKOVFM225E	FKOVFM225F
***250	250	10	-	-	350	248	210	22	405	12	114	12000	FKOVFM280E	FKOVFM280F
***280	250	10	-	-	350	248	210	22	405	12	114	12000	FKOVFM280E	FKOVFM280F
***315	300	8	-	-	400	305	245	22	475	12	114	19000	FKOVFM315E	FKOVFM315F
***355	350	7	-	-	460	330	280	22	530	16	129	26000	FKOVFM355E	FKOVFM355F
***400	400	6	-	-	515	350	306	26	594	16	169	34000	FKOVFM400E	FKOVFM400F
****10"	250	10	-	-	362	248	210	25.4	405	12	114	12000	FKOAVFM810E	FKOAVFM810F
****12"	300	8	-	-	432	305	245	25.4	475	12	114	19000	FKOAVFM812E	FKOAVFM812F
****14"	350	7	-	-	476	330	280	28.5	530	12	129	26000	FKOAVFM814E	FKOAVFM814F
****16"	400	6	-	-	540	350	306	28.5	594	16	169	34000	FKOAVFM816E	FKOAVFM816F

*FKOV d140 with special adapter collars d125

**FKOV d225 with special adapter collars d200

***ISO-DIN

****ANSI B16.5 cl. 150

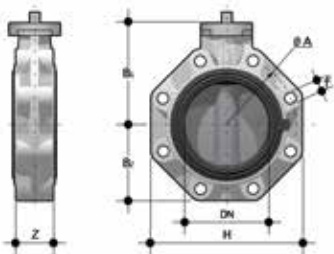

FKOV/FM LUG ISO-DIN

Bare shaft Butterfly valve, version Lug ISO-DIN

d	DN	PN	øA	B ₁	B ₂	f	H	U	Z	g	EPDM Code	FPM Code
75	65	10	145	119	80	M16	165	4	46	1400	FKOLVFM075E	FKOLVFM075F
90	80	10	160	133	93	M16	185	8	49	2200	FKOLVFM090E	FKOLVFM090F
110	100	10	180	147	107	M16	211	8	56	2550	FKOLVFM110E	FKOLVFM110F
140	125	10	210	167	120	M16	240	8	64	4150	FKOLVFM140E	FKOLVFM140F
160	150	10	240	180	134	M20	268	8	70	4900	FKOLVFM160E	FKOLVFM160F
225	200	10	295	227	161	M20	323	8	71	7600	FKOLVFM225E	FKOLVFM225F

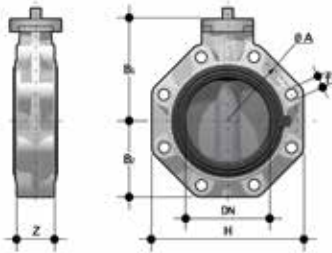

FKOV/FM LUG ANSI

Bare shaft Butterfly valve, version Lug ANSI

d	DN	PN	øA	B ₁	B ₂	f	H	U	Z	g	EPDM Code	FPM Code
2" 1/2	65	10	145	119	80	5/8"	165	4	46	1400	FKOALVFM212E	FKOALVFM212F
3"	80	10	160	133	93	5/8"	185	8	49	2200	FKOALVFM300E	FKOALVFM300F
4"	100	10	180	147	107	5/8"	211	8	56	2550	FKOALVFM400E	FKOALVFM400F
5"	125	10	210	167	120	3/4"	240	8	64	4150	FKOALVFM500E	FKOALVFM500F
6"	150	10	240	180	134	3/4"	268	8	70	4900	FKOALVFM600E	FKOALVFM600F
8"	200	10	295	227	161	3/4"	323	8	71	7600	FKOALVFM800E	FKOALVFM800F
10"	250	6	362	248	210	7/8"	405	12	114	16800	FKOALVFM810E	FKOALVFM810F
12"	300	6	431.8	305	245	7/8"	475	12	114	23800	FKOALVFM812E	FKOALVFM812F

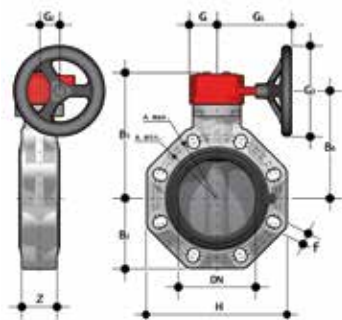

FKOV/RM

Gearbox operated Butterfly valve

d	DN	PN	A _{min}	A _{max}	øA	B ₂	B ₅	B ₆	G	G ₁	G ₂	G ₃	H	U	Z	g	EPDM Code	FPM Code
50	40	16	99	109	-	60	161	133	48	135	39	125	132	4	33	1974	FKOVRM050E	FKOVRM050F
63	50	16	115	125.2	-	70	167	139	48	135	39	125	147	4	43	2154	FKOVRM063E	FKOVRM063F
75	65	10	128	144	-	80	174	146	48	135	39	125	165	4	46	2400	FKOVRM075E	FKOVRM075F
90	80	10	145	160	-	93	188	160	48	135	39	125	185	8	49	2800	FKOVRM090E	FKOVRM090F
110	100	10	165	190	-	107	202	174	48	135	39	125	211	8	56	3150	FKOVRM110E	FKOVRM110F
*125	125	10	204	215	-	120	222	194	48	144	39	200	240	8	64	4450	FKOVRM140E	FKOVRM140F
140	125	10	204	215	-	120	222	194	48	144	39	200	240	8	64	4450	FKOVRM140E	FKOVRM140E
160	150	10	230	242	-	134	235	207	48	144	39	200	268	8	70	5200	FKOVRM160E	FKOVRM160F
**200	200	10	280	298	-	161	287	256	65	204	60	200	323	8	71	9300	FKOVRM225E	FKOVRM225F
225	200	10	280	298	-	161	287	256	65	204	60	200	323	8	71	9300	FKOVRM225E	FKOVRM225F
***250	250	10	-	-	350	210	317	281	88	236	76	250	405	12	114	18600	FKOVRM280E	FKOVRM280F
***280	250	10	-	-	350	210	317	281	88	236	76	250	405	12	114	18600	FKOVRM280E	FKOVRM280F
***315	300	8	-	-	400	245	374	338	88	236	76	250	475	12	114	25600	FKOVRM315E	FKOVRM315F
***355	350	7	-	-	460	280	438	390	88	361	80	300	530	16	129	34450	FKOVRM355E	FKOVRM355F
***400	400	6	-	-	515	306	438	390	88	361	80	300	594	16	169	42450	FKOVRM400E	FKOVRM400F
****10"	250	10	-	-	362	210	317	281	88	236	76	250	405	12	114	18600	FKOAVRM810E	FKOAVRM810F
****12"	300	8	-	-	432	245	374	338	88	236	76	250	475	12	114	25600	FKOAVRM812E	FKOAVRM812F
****14"	350	7	-	-	476	280	438	390	88	361	80	300	530	12	129	34450	FKOAVRM814E	FKOAVRM814F
****16"	400	6	-	-	540	306	438	390	88	361	80	300	594	16	169	42450	FKOAVRM816E	FKOAVRM816F

*FKOV d140 with special adapter collars d125

**FKOV d225 with special adapter collars d200

***ISO-DIN

****ANSI B16.5 cl. 150

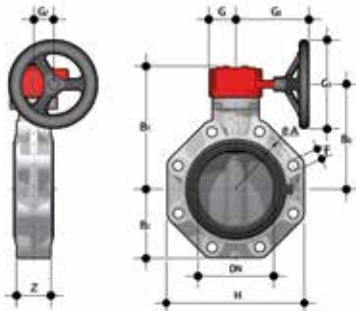

FKOV/RM LUG ISO-DIN

Gearbox operated Butterfly valve, version Lug ISO-DIN

d	DN	PN	øA	B ₂	B ₃	B ₆	f	G	G ₁	G ₂	G ₃	H	U	Z	g	EPDM Code	FPM Code
75	65	10	145	80	174	146	M16	48	135	39	125	165	4	46	2800	FKOLVRM075E	FKOLVRM075F
90	80	10	160	93	188	160	M16	48	135	39	125	185	8	49	3600	FKOLVRM090E	FKOLVRM090F
110	100	10	180	107	202	174	M16	48	135	39	125	211	8	56	3950	FKOLVRM110E	FKOLVRM110F
140	125	10	210	120	222	194	M16	48	144	39	200	240	8	64	6050	FKOLVRM140E	FKOLVRM140F
160	150	10	240	134	235	207	M20	48	144	39	200	268	8	70	6800	FKOLVRM160E	FKOLVRM160F
225	200	10	295	161	287	256	M20	65	204	60	200	323	8	71	10900	FKOLVRM225E	FKOLVRM225F

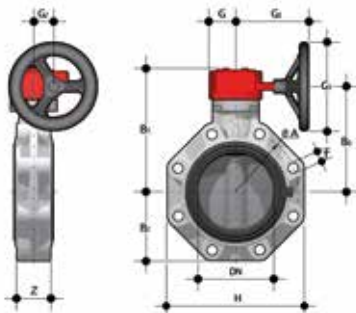

FKOV/RM LUG ANSI

Gearbox operated Butterfly valve, version Lug ANSI

d	DN	PN	øA	B ₂	B ₃	B ₆	f	G	G ₁	G ₂	G ₃	H	U	Z	g	EPDM Code	Code
2" 1/2	65	10	139.7	80	174	146	5/8"	48	135	39	125	165	4	46	2800	FKOALVRM212E	FKOALVRM212F
3"	80	10	152.4	93	188	160	5/8"	48	135	39	125	185	8	49	3600	FKOALVRM300E	FKOALVRM300F
4"	100	10	190.5	107	202	174	5/8"	48	135	39	125	211	8	56	3950	FKOALVRM400E	FKOALVRM400F
5"	125	10	215.9	120	222	194	3/4"	48	144	39	200	240	8	64	6050	FKOALVRM500E	FKOALVRM500F
6"	150	10	241.3	134	235	207	3/4"	48	144	39	200	268	8	70	6800	FKOALVRM600E	FKOALVRM600F
8"	200	10	298.4	161	287	256	3/4"	65	204	60	200	323	8	71	10900	FKOALVRM800E	FKOALVRM800F
10"	250	6	362	210	317	281	7/8"	88	236	76	250	405	12	114	23400	FKOALVRM810E	FKOALVRM810F
12"	300	6	431.8	245	374	338	7/8"	88	236	76	250	475	12	114	30400	FKOALVRM812E	FKOALVRM812F

ACCESSORIES

FK MS

The MS kit lets you install a limit switch with electromechanical or inductive micro switches on a manual FK/LM valve to remotely signal the valve position (open-closed). The kit can be assembled on the valve even if already installed on the system.

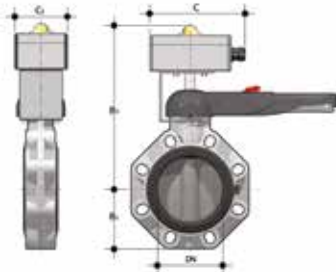

DN	B ₂	B ₃	C ₁	Protection rate	Electromechanical code	Inductive code	Namur code
40	60	248	80	IP67	FKMS0M	FKMS0I	FKMS0N
50	70	254	80	IP67	FKMS0M	FKMS0I	FKMS0N
65	80	261	80	IP67	FKMS0M	FKMS0I	FKMS0N
80	93	275	80	IP67	FKMS1M	FKMS1I	FKMS1N
100	107	289	80	IP67	FKMS1M	FKMS1I	FKMS1N
125	120	309	80	IP67	FKMS1M	FKMS1I	FKMS1N
150	134	322	80	IP67	FKMS1M	FKMS1I	FKMS1N
200	161	369	80	IP67	FKMS2M	FKMS2I	FKMS2N

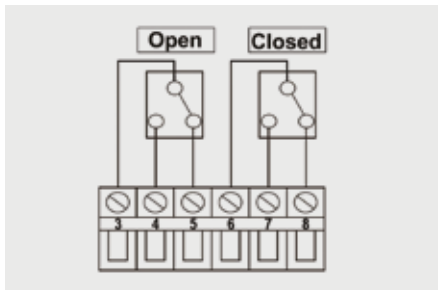

Electromechanical

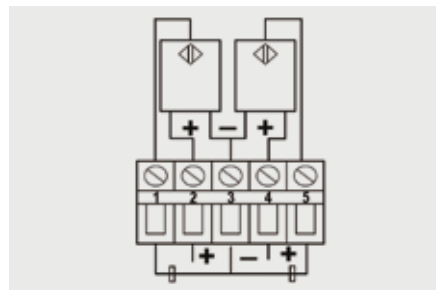

Inductive

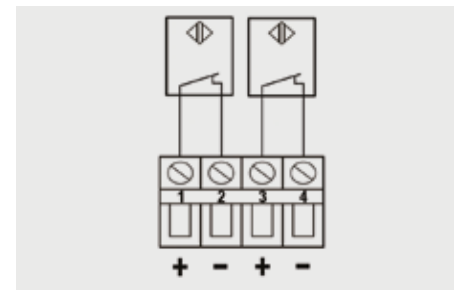

Namur

LSE

Customisation set and label printing for Easyfit handle made up of precut adhesive sheets and software for guided label creation.



DN	Code
40	LSE040
50	LSE040
65	LSE040
80	LSE040
100	LSE040
125	LSE040
150	LSE040
200	LSE040

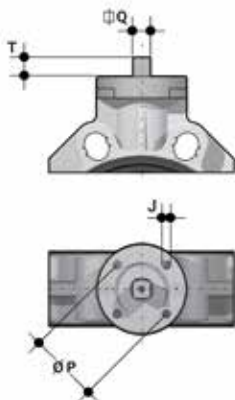

Actuator mounting flange

The valve can be equipped with standard pneumatic or electric actuators and gearbox for heavy-duty operations, using a flange in PP-GR reproducing the drilling pattern provided for by standard ISO 5211.

DN	J	P	Ø	T	Q
40	7	50	F 05	12	11
50	7	50	F 05	12	11
65	7/9	50/70	F 05/F 07	12	11
80	9	70	F 07	16	14
100	9	70	F 07	16	14
125	9	70	F 07	19	17
150	9	70	F 07	19	17
200	11	102	F 10	24	22
200	11	102	F 10	24	22
250	11/13/17	102/125/140	F 10/F 12/F 14	29	27
300	11/13/17	102/125/140	F 10/F 12/F 14	29	27
350	14/18	125/140	F 12/F 14	29	27
400	14/18	125/140	F 12/F 14	29	27

CUSTOMISATION

The FK valve is equipped with the customisable Labelling System.

This system lets you create special labels to insert in the handle. This makes it extremely easy to apply company logos, identification serial numbers or service indications such as, for example, the valve function in the system, the transported fluid, but also specific information for customer service, such as the customer name or installation date or location on the valves.

The specific LCE module is a standard supply and is made up of a rigid transparent water-resistant PVC plug (A-C) and white tag holder (B) made of the same material, one side of which bears the FIP logo (fig. 1).

The tag holder, inserted in the plug, can be removed and, once overturned, used for customisation by applying labels printed with the software supplied with the LSE set. Proceed as follows to apply the label on the valve:

- 1) Remove the upper part of the transparent plug (A) rotating it counter-clockwise as indicated by the word "Open" on the plug and remove it.
- 2) Extract the tag holder from its housing on the lower part of the plug (C).
- 3) Apply the adhesive label on the holder (B) to align the profiles matching the tab position.
- 4) Reinsert the tag holder in its housing at the bottom of the plug.
- 5) Reposition the top of the plug in the housing rotating it clockwise; this way the label is protected against the elements.

Fig. 1

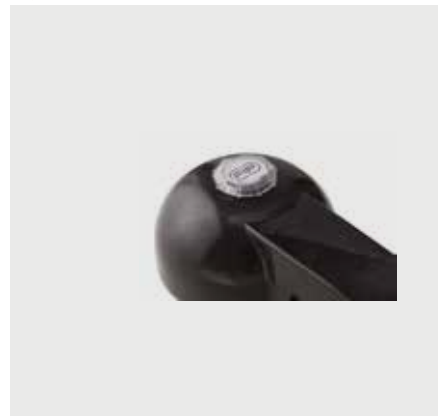
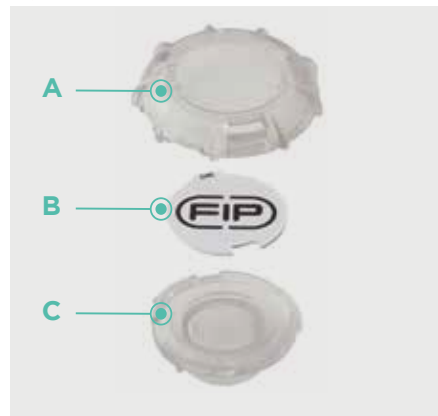
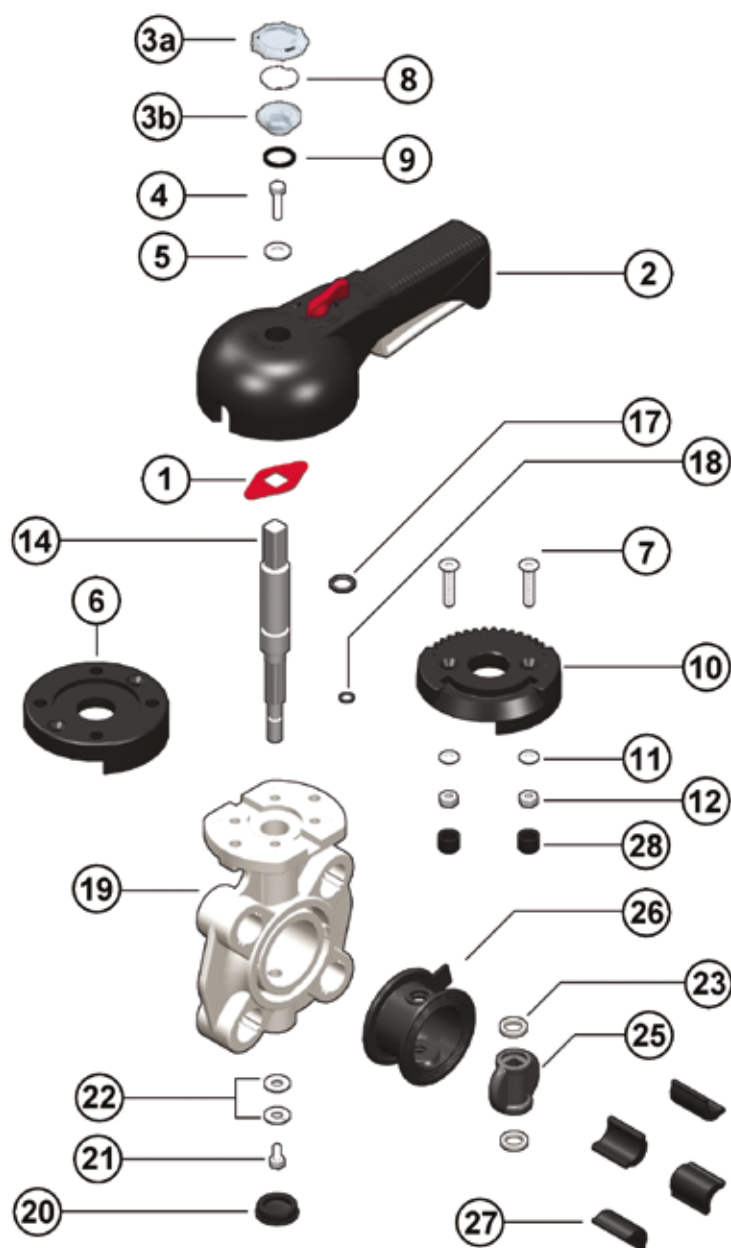

Fig. 2



COMPONENTS

EXPLODED VIEW DN 40÷50



- | | | |
|---|---|---|
| 1 · Position indicator (PA - 1) | 10 · Plate (PP-GR - 1) | 20 · Protection plug (PE - 1) |
| 2 · Handle (HIPVC - 1) | 11 · Washer (STAINLESS Steel - 2) | 21 · Screw ((STAINLESS steel - 1) |
| 3a/b · Transparent protection plug (PVC - 1) | 12 · Nut (STAINLESS Steel - 2) | 22 · Washer (STAINLESS steel - 1) |
| 4 · Fastening screw (STAINLESS steel - 1) | 13 · Seeger ring (STAINLESS steel - 1) | 23 · Anti-friction ring (PTFE - 2) |
| 5 · Washer (STAINLESS Steel - 1) | 14 · Stem (STAINLESS steel 316 - 1) | 24 · Disk O-Ring (FPM - 2) |
| 6 · Flange (PP-GR - 1) | 15 · Bush O-Ring (FPM - 2) | 25 · Disk (PVC-U- 1) |
| 7 · Screw (STAINLESS Steel - 2) | 16 · Bush (Nylon - 1) | 26 · Liner (EPDM or FPM - 1) |
| 8 · Tag holder (PVC-U - 1) | 17 · Stem O-Ring (FPM - 1) | 27 · Inserts (ABS - 4-8) |
| 9 · O-Ring (NBR - 1) | 18 · Stem O-Ring (FPM - 1) | 28 · Plug (PE - 2) |
| | 19 · Body (PP-GR - 1) | |

The component material and quantity supplied are indicated in the parentheses.

EXPLODED VIEW DN 65÷200

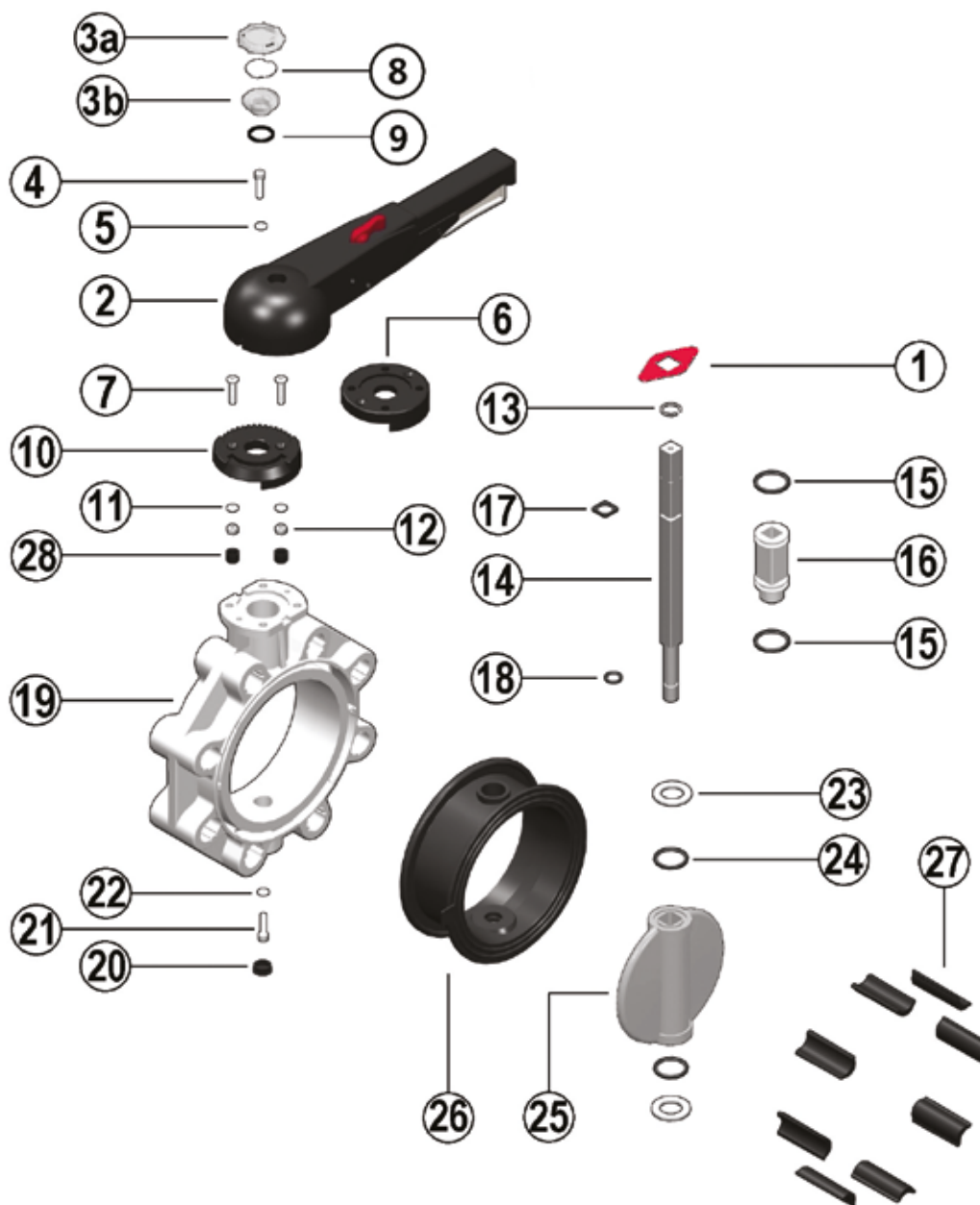

- | | | |
|---|---|---|
| 1 · Position indicator (PA - 1) | 9 · O-Ring (NBR - 1) | 19 · Body (PP-GR - 1) |
| 2 · Handle (HIPVC - 1) | 10 · Plate (PP-GR - 1) | 20 · Protection plug (PE - 1) |
| 3a/b · Transparent protection plug (PVC - 1) | 11 · Washer (STAINLESS Steel - 2) | 21 · Screw ((STAINLESS steel - 1) |
| 4 · Fastening screw (STAINLESS steel - 1) | 12 · Nut (STAINLESS Steel - 2) | 22 · Washer (STAINLESS steel - 1) |
| 5 · Washer (STAINLESS Steel - 1) | 13 · Seeger ring (STAINLESS Steel - 1) | 23 · Anti-friction ring (PTFE - 2) |
| 6 · Flange (PP-GR - 1) | 14 · Stem (STAINLESS steel 316 - 1) | 24 · Disk O-Ring (FPM - 2) |
| 7 · Screw (STAINLESS Steel - 2) | 15 · Bush O-Ring (FPM - 2) | 25 · Disk (PVC-U - 1) |
| 8 · Tag holder (PVC-U - 1) | 16 · Bush (Nylon - 1) | 26 · Liner (EPDM o FPM - 1) |
| | 17 · Stem O-Ring (FPM - 1) | 27 · Inserts (ABS - 4-8) |
| | 18 · Stem O-Ring (FPM - 1) | 28 · Plug (PE - 2) |

The component material and quantity supplied are indicated in the parentheses.

EXPLODED VIEW DN 250÷300

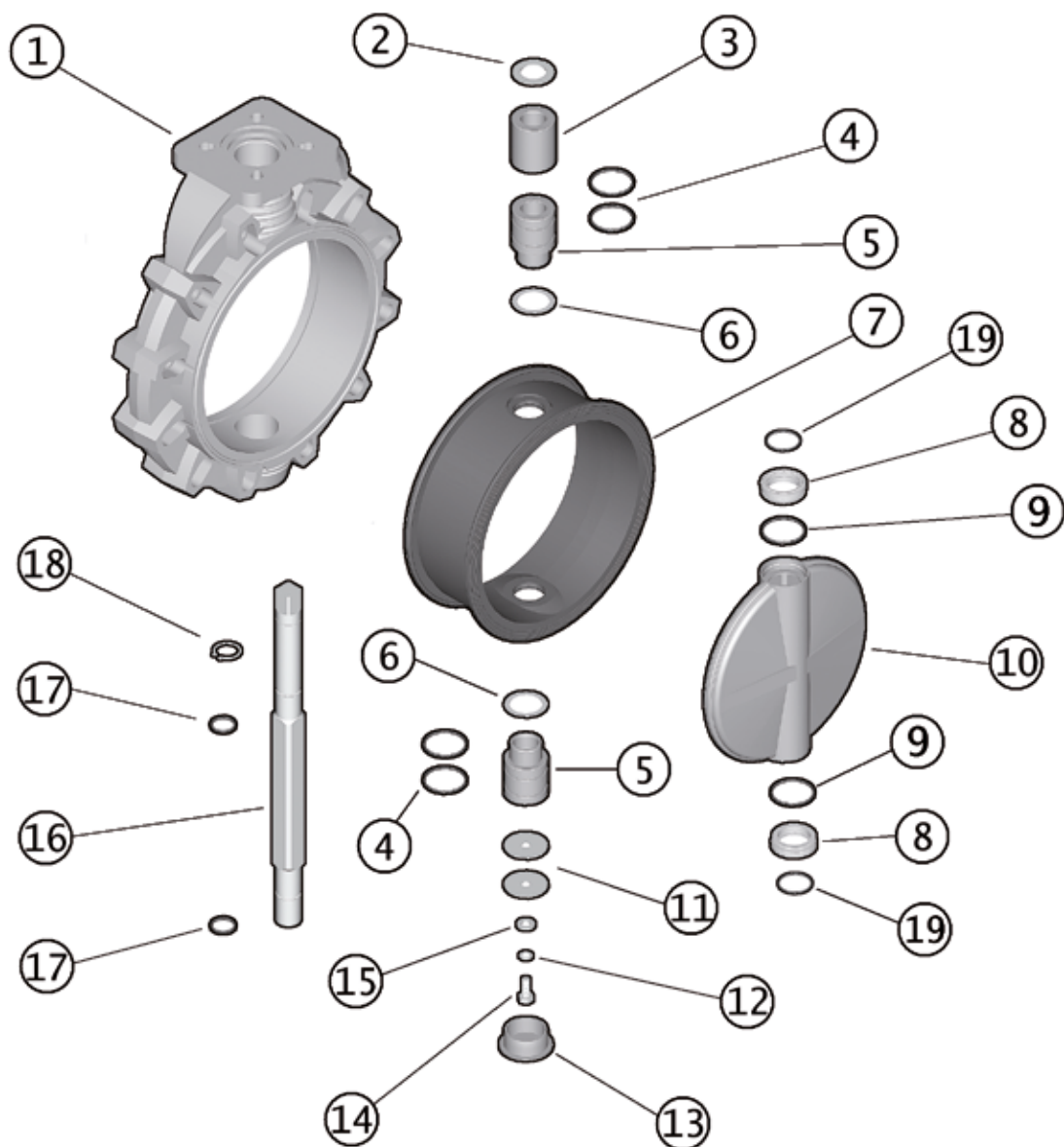

- | | | |
|----------------------------------|-----------------------------------|--|
| 1 · Body (PP-GR - 1) | 8 · Anti-friction ring (PTFE - 2) | 16 · Stem (STAINLESS steel 316 - 1) |
| 2 · Washer (STAINLESS Steel - 1) | 9 · Disk O-Ring (FPM - 2) | 17 · Stem O-Ring (FPM - 2) |
| 3 · Bush (PP - 1) | 10 · Disk (PVC-U - 1) | 18 · Seeger ring (STAINLESS steel - 1) |
| 4 · Bush O-Ring (FPM - 4) | 11 · Washer (STAINLESS Steel - 2) | 19 · O-Ring (FPM - 2) |
| 5 · Bush (PP - 2) | 12 · Washer (STAINLESS Steel - 1) | |
| 6 · Washer (PTFE - 2) | 13 · Protection plug (PE - 1) | |
| 7 · Liner (EPDM o FPM - 1) | 14 · Screw ((STAINLESS steel - 1) | |
| | 15 · Washer (STAINLESS Steel - 1) | |

The component material and quantity supplied are indicated in the parentheses.

EXPLODED VIEW DN 350÷400

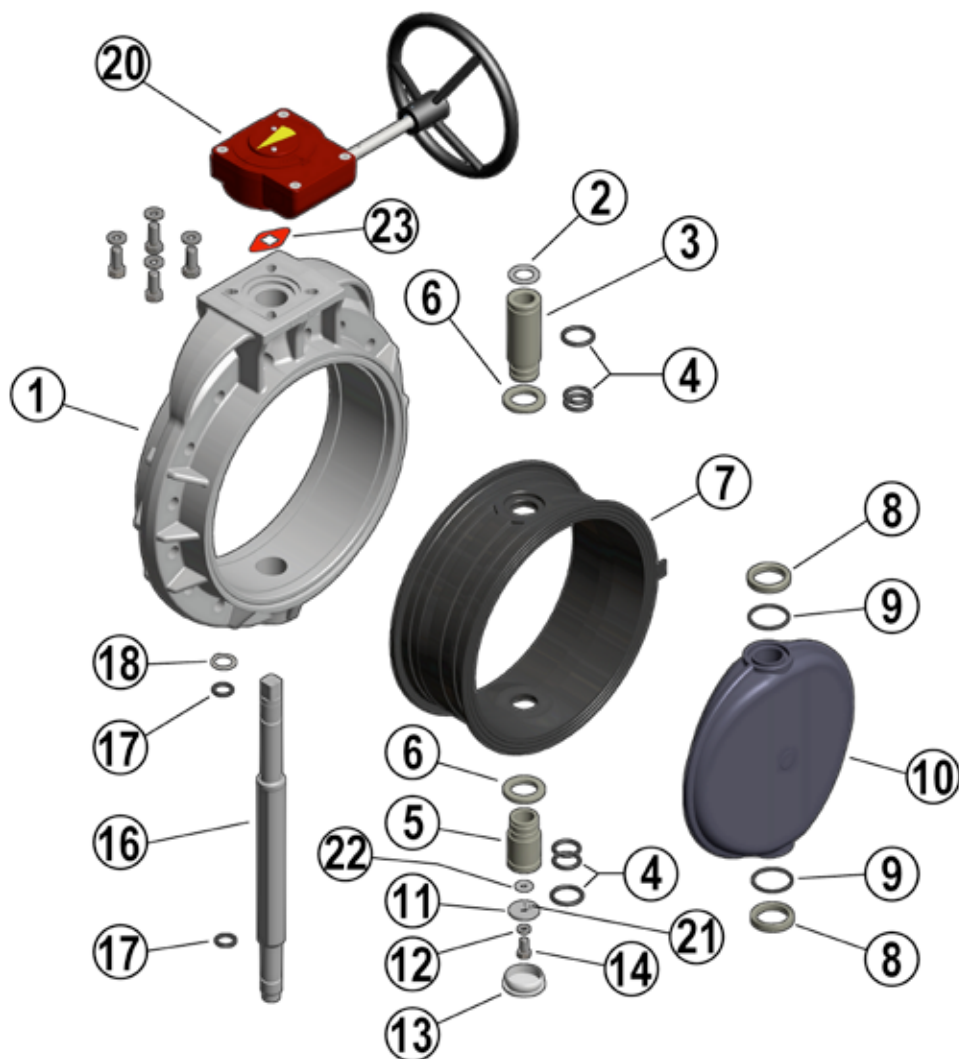

- | | | |
|-----------------------------------|---|--|
| 1 · Body (PP-GR - 1) | 9 · Disk O-Ring (EPDM or FPM - 2) | 18 · Seeger ring (STAINLESS steel - 1) |
| 2 · Washer (STAINLESS Steel - 1) | 10 · Disk (PVC-U - 1) | 20 · Gearbox (Al, Steel - 1) |
| 3 · Bush (PP-H - 1) | 11 · Washer (STAINLESS Steel - 1) | 21 · Pin (STAINLESS steel - 2) |
| 4 · Bush O-Ring (EPDM or FPM - 6) | 12 · Washer (STAINLESS Steel - 1) | 22 · Washer (STAINLESS steel - 1) |
| 5 · Bush (PP-H - 1) | 13 · Protection plug (PE - 1) | 23 · Position indicator (PA - 1) |
| 6 · Washer (PP-H - 2) | 14 · Screw (Screw (STAINLESS steel - 1) | |
| 7 · Liner (EPDM or FPM - 1) | 16 · Stem (STAINLESS steel 316 - 1) | |
| 8 · Anti-friction ring (PTFE - 2) | 17 · Stem O-Ring (EPDM or FPM - 2) | |

The component material and quantity supplied are indicated in the parentheses.

DISMOUNTING

DN 40÷200

- 1) Remove the LCE module consisting of the rigid transparent PVC plug (3a-3b) and white tag holder (8) and remove screw (2) and washer (3) (fig.3).
- 2) Remove the handle (2).
- 3) Remove the screws (7) and plate (10) from the body (19).
- 4) Remove the protection plug (20) and screw (21) with the washer (22).
- 5) Extract the stem (14) and disk (25).
- 6) Remove the anti-friction rings (23) and (DN 65÷200 only) O-Rings (24).
- 7) Remove the liner (26) from the body (19).
- 8) Remove the Seeger ring (13) and (DN 65÷200 only) guide bush (16).
- 9) Remove (DN 65÷200 only) the O-Rings (15) and (17, 18).

DN 250÷300

- 1) Remove the protection plug (13) and screw (14) with the washers (11-15).
- 2) Extract the stem (16) and disk (10).
- 3) Remove the seal (7) from the body (1).
- 4) Remove the Seeger ring (18) and guide bushes (5-3) with washer (2).
- 5) Extract the lower bush (5).
- 6) Remove O-Rings (4) and (17).

DN 350÷400

1. Remove the position indicator (23) from the stem (16).
2. Remove the protection plug (13) from the body (1).
3. Remove the screw (14) and the washers (11) and (22).
4. Extract the stem unit (16) from the disk.
5. Extract the lower bush unit (5) from the lower part of the body (1).
6. Remove the disk unit (10) from the body (1).

ASSEMBLY

DN 40÷200

- 1) Place the liner (26) on the body (19).
- 2) Insert the O-Rings (17) and (18) on the stem (14).
- 3) Insert the O-Rings (15) on the guide bush (16) and the bush on the stem. Lock the bush using the Seeger ring (13).
- 4) Position the O-Rings (24) and then the anti-friction rings (23) on the disk (25) and the disk inside the body, after having lubricated the liner (26).
- 5) Insert the through stem (14) in the body (19) and disk (25).
- 6) Tighten screw (21) with washer (22) and insert the protection plug (20).
- 7) Position the plate (10) on the body (19) and tighten screws (7).
- 8) Position the handle (2) on the stem (14).
- 9) Tighten screw (4) with washer (5) and replace the LCE module consisting of the rigid transparent PVC plug (3a-3b) and white tag holder (8).

DN 250÷300

- 1) Place the liner (7) on the body (1).
- 2) Insert the O-Rings (4) and washer (6) on bushes (5).
- 3) Insert the O-Rings (17) on the stem (16); insert the upper bush (5), bush (3), washer (2) on the stem and fix them with Seeger ring (18).
- 4) Insert the seals (19-9) on the anti-friction rings (8).
- 5) Position the washers (8) in the housings on the disk (10), and the disk inside the body (1) after having lubricated the liner (7).
- 6) Insert the through stem (16) in the body and disk.
- 7) Position the lower bush (5) from below.
- 8) Tighten screws (14) with washers (11-15) and insert the protection plug (13).

DN 350÷400

1. Insert the lower bush (5) complete with O-rings (4) on the body (1), subsequently inserting the gland packing washer (6) between the bush and the body.
2. Insert the second gland packing washer (6) on the liner (7) and fit these inside the body (1).
3. Insert the O-rings (9) and anti-friction rings (8) on the disks (10).
4. Lubricate the disk (10) and insert it into the liner (7).

5. Insert the upper bush complete with O-rings (3 + 4) on the stem (16) joined to the O-rings (17); insert the washer (2) above the upper bush (3) and insert Seeger ring (18) in the appropriate housing on the stem (16). Insert this unit in the body's upper hole (1).
6. Overlap washer (22) on washer (11) equipped with pins (21), and insert this unit on the lower part of the stem (16), fastening it with screw (14) and locking washer (12).
7. Insert the protection plug (13) on the body (1).
8. Insert the position indicator (23) on the upper part of the stem (16).



Note: during assembly operations, it is advisable to lubricate the rubber seals. Mineral oils are not recommended for this task as they react aggressively with EPDM rubber.

Fig. 3



INSTALLATION

JOINTS

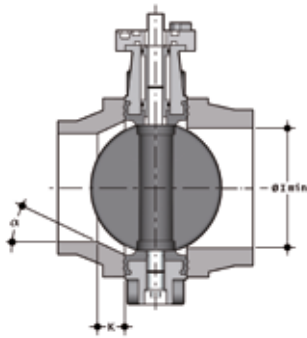

Before proceeding with the installation of the stubs, check that the bore of the fittings has sufficient clearance to allow the valve disk to open correctly. Also check the maximum coupling distance for the liner. Before proceeding with the installation of the FK valve, check that the bore of the stub allows the correct opening of the disk.

DN	l min.
40	25
50	28
65	47
80	64
100	84
125	108
150	134
200	187
250	225
300	280
350	324
400	362

To install on PVC-U collars, check the valve-collar-flange couplings in the following table.

	d	DN	50	63	75	90	110	125	140	160	180	200	225	250	280	315	355	400			
			40	50	65	80	100	100	125	150	150	200	200	250	250	300	350	400			
FK valve	50	40																			
	63	50																			
	75	65																			
	90	80																			
	110	100																			
	140	125						*													
	160	150																			
	225	200											**								
	280	250																			
	315	300																			
	355	350																			
	400	400																			

Stub with female end for solvent welding according to EN ISO 1452 and DIN 8063- 4

* With special collar d125 DN125 for FK d140 DN125 and flange d140 DN125

** With special collar d200 DN200 for FK d225 DN200 and flange d225 DN200

POSITIONING THE VALVE

Position the valve between two flanged stubs, taking care to respect the installation tolerances Z. It is advisable to always install the valve with the disk partially closed (it must not exit the body) and avoid any misalignment of the flanges, as this would cause leaks.

Where possible comply with the following requirements:

- Conveying dirty fluids: position the valve with the stem inclined at an angle of 45° to the pipe support plane.
- Conveying fluids with sediment: position the valve with the stem parallel to the pipe support plane.
- Conveying clean fluids: position the valve with the stem perpendicular to the pipe support plane.

TIGHTENING THE STUD-BOLTS



Before tightening the stud-bolts, it is advisable to open the disk in order to prevent damage to the seal. Tighten the stud-bolts in a uniform manner, in the order indicated in the figure, to the nominal operating torque value indicated in the table.

The stud-bolts do not need to be excessively tightened in order to produce a perfect hydraulic seal. Overtightening could adversely affect the operating torque of the valve.

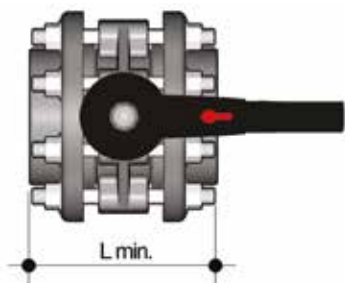

DN	L min.	*Nm
40	M16x150	9
50	M16x150	12
65	M16x170	15
80	M16x180	18
100	M16x180	20
125	M16x210	35
150	M20x240	40
200	M20x260	55
250	M20x310	70
300	M20x340	70
350	M20x360	75
400	M24x420	75

* Tightening torques for nuts and bolts on couplings with backing rings. Values required to obtain the hydraulic test seal (1.5xPN at 20°C) (new or lubricated nuts and bolts)

HANDLE LOCK



Thanks to the multifunctional handle and the red manoeuvre button on the lever, you can perform a 0°-90° operation and a graduated operation by means of the 10 intermediate positions and a stop lock: the handle can be locked in each of the 10 positions by simply pressing the Free-lock button. A lock can also be installed on the handle to protect the system against tampering.

The valve is two-way and can be installed in any position. It can also be installed at end line or tank.

WARNINGS

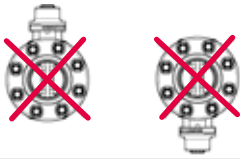

NO
OK

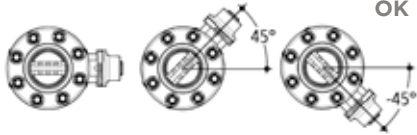

Make sure that the valves installed on the system are suitably supported for their weight.

Always avoid sudden closing manoeuvres and protect the valve from accidental operations. To this end, it is advisable to install a reduction gear, available on request.

In the case of dirty fluids or those with sediments, install the valve inclined as shown in the figure.