

*Aliaxis*



**DK DN 15÷65**  
PP-H

DIALOCK® 2-way diaphragm valve

# DK DN 15÷65

The DK DIALOCK® diaphragm valve is particularly suitable for shutting off and regulating abrasive or dirty fluids.

The new internal geometry of the body optimises fluid dynamic efficiency by increasing the flow rate and ensuring an optimum linearity of the flow adjustment curve.

The DK is extremely compact and very light.

The innovative handwheel is equipped with a patented immediate and ergonomic operating locking device that allows it to be adjusted and locked in any position.

## DIALOCK® 2-WAY DIAPHRAGM VALVE

- Connection system for solvent welding and for threaded and flanged joints.
- **Optimised fluid dynamic design:** maximum output flow rate thanks to the optimised efficiency of the fluid dynamics that characterise the new internal geometry of the body.
- **Internal components in metal, totally isolated from the fluid** and external environment.
- **Modularity of the range:** only 2 handwheel and 4 diaphragm and bonnet sizes for 7 different valve sizes.
- Handwheel that stays at the same height during rotation. It is also fitted with a graduated optical indicator protected by a transparent PVC cap with seal O-Ring.
- Bonnet fastening screws in STAINLESS steel protected by PE plugs. Absence of metal parts exposed to the external environment to prevent any risk of corrosion.
- **New flanged bodies:** the new bodies, characterised by a monolithic flanged structure, are available in PVC-U, PVC-C, PP-H and PVDF. This design, free from body and flange joints, greatly reduces mechanical stress and increases system performance.
- CDSA (Circular Diaphragm Sealing Angle) system that, thanks to the uniform distribution of shutter pressure on the diaphragm seal, offers the following advantages:
  - operating torque reduction
  - reduced mechanical stress on all valve components (actuator, body and diaphragm)
  - low risk of the accumulation of deposits, contamination or damage to the diaphragm due to crystallisation
  - easy to clean valve interior

### Technical specifications

<b>Construction</b>	Diaphragm valve with maximised flow rate and DIALOCK® lockable handwheel
<b>Size range</b>	DN 15 ÷ 65
<b>Nominal pressure</b>	PN 10 with water at 20° C
<b>Temperature range</b>	0 °C ÷ 100 °C
<b>Coupling standards</b>	<b>Welding:</b> EN ISO 15494. Can be coupled to pipes according to EN ISO 15494 <b>Thread:</b> ISO 228-1, DIN 2999 <b>Flanging system:</b> ISO 7005-1, EN 1092-1, EN ISO 15494, EN 558-1, DIN 2501, ANSI B16.5 cl.150
<b>Reference standards</b>	<b>Construction criteria:</b> EN ISO 16138, EN ISO 15494 <b>Test methods and requirements:</b> ISO 9393 <b>Installation criteria:</b> DVS 2202-1, DVS 2207-11, DVS 2208-1, UNI 11318
<b>Valve material</b>	<b>Body:</b> PP-H <b>Bonnet and handwheel:</b> PP-GR <b>Position indicator cap</b> PVC
<b>Diaphragm material</b>	EPDM, FPM, PTFE (on request NBR)
<b>Control options</b>	Manual control; pneumatic actuator

**Dialock®**

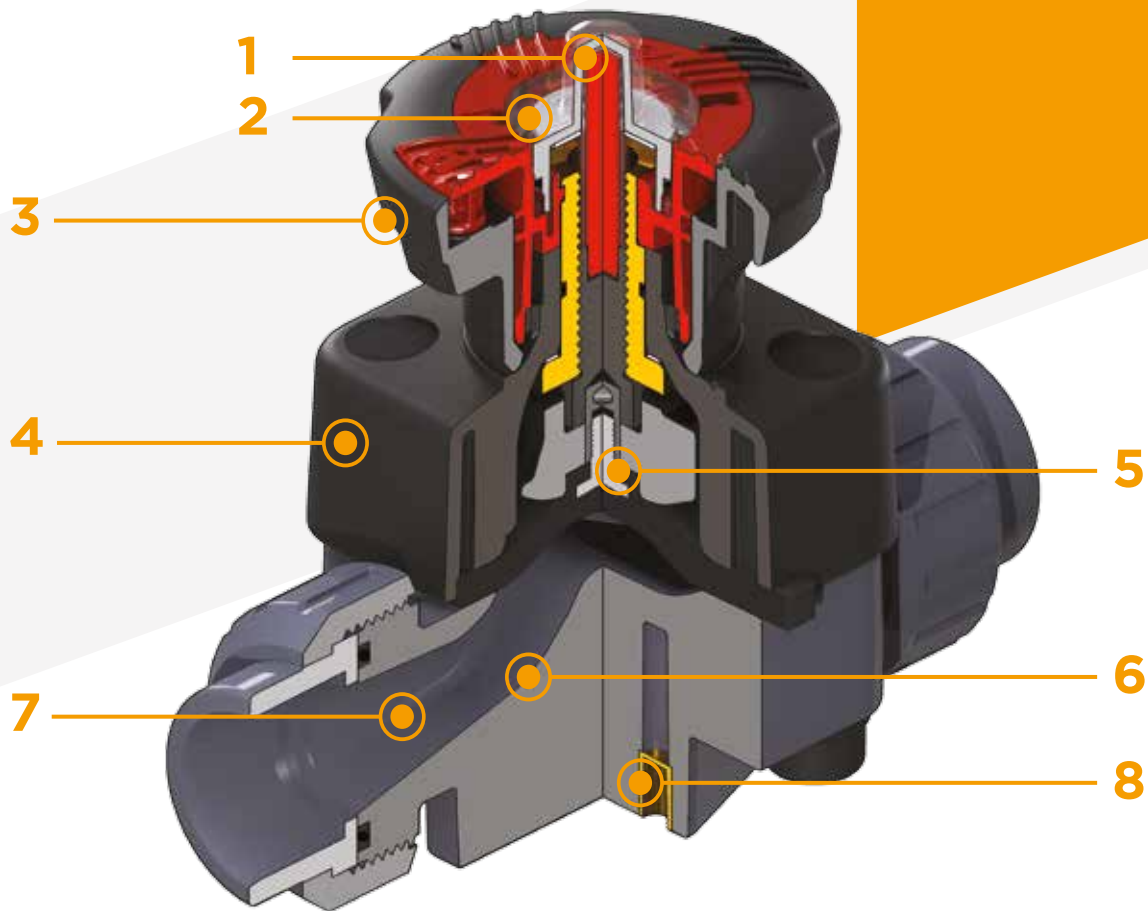

**1 High visibility graduated optical position indicator** protected by a transparent cap with seal O-Ring

**2 Customisation plate.** The customisation lets you identify the valve on the system according to specific needs

**3 DIALOCK® SYSTEM:** innovative handwheel with a patented **immediate and ergonomic locking device** that allows it to be adjusted and **locked in over 300 positions**

**4 Handwheel and bonnet** in high mechanical strength and chemically resistant **PP-GR**, providing **full protection** by isolating all internal metal parts from contact with external agents

**5 Floating pin connection** between the control screw and diaphragm to prevent concentrated loads, improve the seal and extend its lifetime

**6 New design of valve body interior:** substantially increased flow coefficient and reduced pressure drop. The degree of efficiency reached has also **enabled the size and weight of the valve to be reduced.**

**7 Adjustment linearity:** the internal profiles of the valve also greatly improve its characteristic curve, resulting in **extremely sensitive and precise adjustment** along the entire stroke of the shutter

**8 Valve anchoring bracket integrated in the body,** with threaded metal inserts allowing **simple panel or wall mounting** using the PMDK mounting plate (supplied as an accessory)

# TECHNICAL DATA

## PRESSURE VARIATION ACCORDING TO TEMPERATURE

For water and non-hazardous fluids with regard to which the material is classified as CHEMICALLY RESISTANT. In other cases, a reduction of the nominal pressure PN is required (25 years with safety factor).

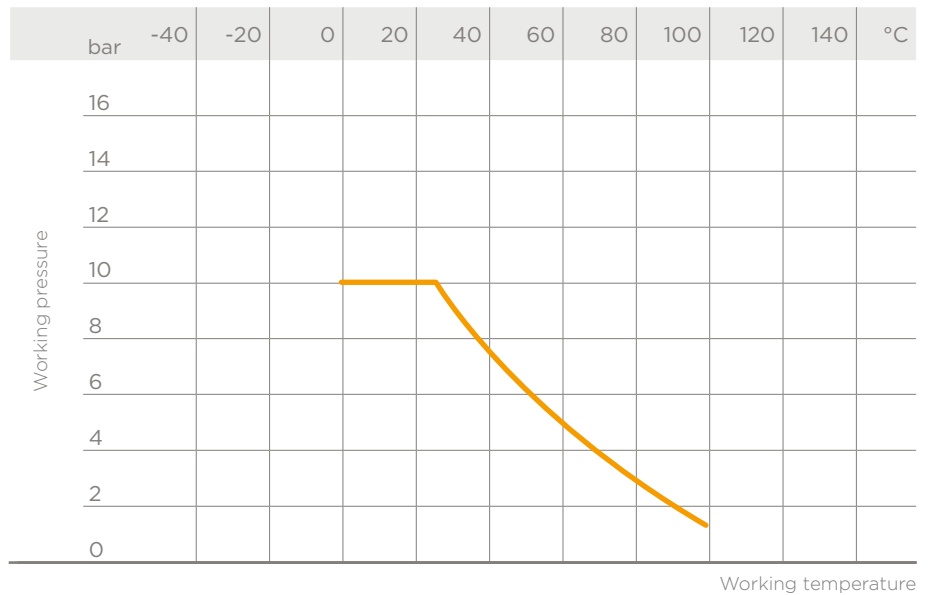

## PRESSURE DROP GRAPH

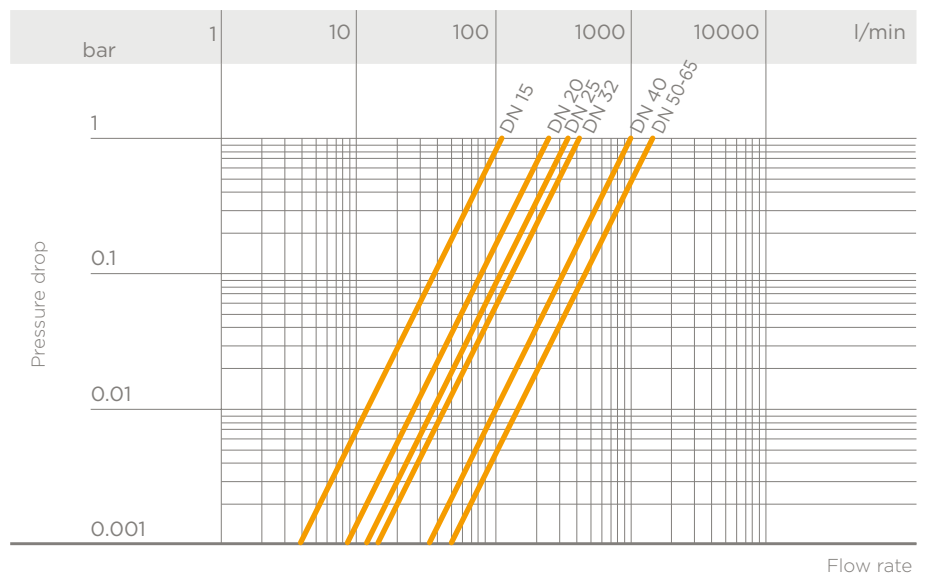

## K<sub>v</sub>100 FLOW COEFFICIENT

The K<sub>v</sub>100 flow coefficient is the Q flow of litres per minute of water at a temperature of 20°C that will generate Δp= 1 bar pressure drop at a certain valve position.

The K<sub>v</sub>100 values shown in the table are calculated with the valve completely open.

DN	15	20	25	32	40	50	65
K <sub>v</sub> 100 l/min	112	261	445	550	1087	1648	1600

## RELATIVE FLOW COEFFICIENT GRAPH

The relative flow coefficient is the flow rate through the valve as a function of the degree of valve opening.

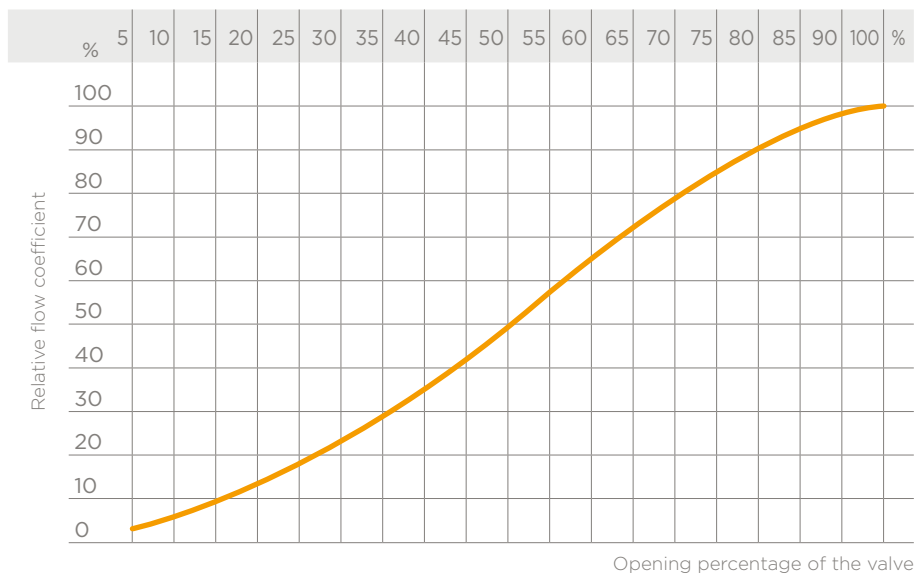

# DIMENSIONS

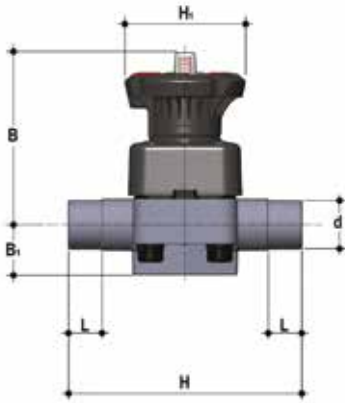

## DKDM

DIALOCK® Diaphragm valve with male ends for socket welding, metric series

d	DN	PN	B	B <sub>1</sub>	H	H <sub>1</sub>	L	g	Code EPDM	Code FPM	Code PTFE
20	15	10	102	25	124	80	16	430	DKDM020E	DKDM020F	DKDM020P
25	20	10	105	30	144	80	19	445	DKDM025E	DKDM025F	DKDM025P
32	25	10	114	33	154	80	22	620	DKDM032E	DKDM032F	DKDM032P
40	32	10	119	30	174	80	26	650	DKDM040E	DKDM040F	DKDM040P
50	40	10	149	35	194	120	31	1380	DKDM050E	DKDM050F	DKDM050P
63	50	10	172	46	224	120	38	2136	DKDM063E	DKDM063F	DKDM063P
75	65	10	172	46	284	120	44	2225	DKDM075E	DKDM075F	DKDM075P

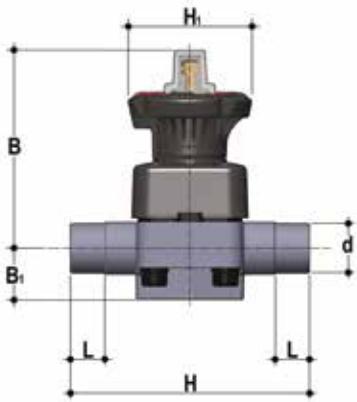

## DKLDM

DIALOCK® diaphragm valve with stroke limiter and male ends for socket welding, metric series

d	DN	PN	B	B <sub>1</sub>	H	H <sub>1</sub>	L	g	Code EPDM	Code FPM	Code PTFE
20	15	10	115	25	124	80	16	460	DKLDM020E	DKLDM020F	DKLDM020P
25	20	10	118	30	144	80	19	475	DKLDM025E	DKLDM025F	DKLDM025P
32	25	10	127	33	154	80	22	650	DKLDM032E	DKLDM032F	DKLDM032P
40	32	10	132	30	174	80	26	680	DKLDM040E	DKLDM040F	DKLDM040P
50	40	10	175	35	194	120	31	1440	DKLDM050E	DKLDM050F	DKLDM050P
63	50	10	200	46	224	120	38	2196	DKLDM063E	DKLDM063F	DKLDM063P
75	65	10	200	46	284	120	44	2285	DKLDM075E	DKLDM075F	DKLDM075P

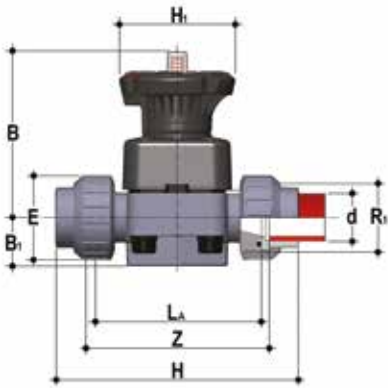

## DKUIM

DIALOCK® Diaphragm valve with female union ends for socket welding, metric series

d	DN	PN	B	B <sub>1</sub>	E	H	H <sub>1</sub>	L <sub>A</sub>	R <sub>1</sub>	Z	g	Code EPDM	Code FPM	Code PTFE
20	15	10	102	25	41	129	80	90	1"	100	457	DKUIM020E	DKUIM020F	DKUIM020P
25	20	10	105	30	50	154	80	108	1 1/4"	116	500	DKUIM025E	DKUIM025F	DKUIM025P
32	25	10	114	33	58	168	80	116	1 1/2"	124	695	DKUIM032E	DKUIM032F	DKUIM032P
40	32	10	119	30	72	192	80	134	2"	140	781	DKUIM040E	DKUIM040F	DKUIM040P
50	40	10	149	35	79	222	120	154	2 1/4"	160	1557	DKUIM050E	DKUIM050F	DKUIM050P
63	50	10	172	46	98	266	120	184	2 3/4"	190	2293	DKUIM063E	DKUIM063F	DKUIM063P

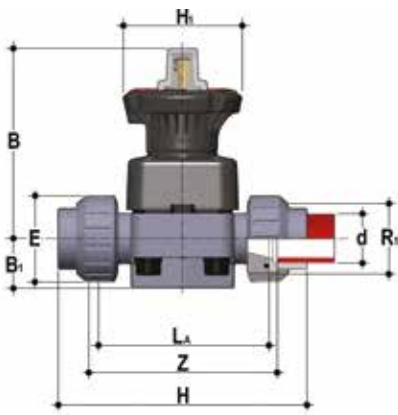

## DKLUIM

DIALOCK® Diaphragm valve with stroke limiter and female union ends for socket welding, metric series

d	DN	PN	B	B <sub>1</sub>	E	H	H <sub>1</sub>	L <sub>A</sub>	R <sub>1</sub>	Z	g	Code EPDM	Code FPM	Code PTFE
20	15	10	115	25	41	129	80	90	1"	100	487	DKLUIM020E	DKLUIM020F	DKLUIM020P
25	20	10	118	30	50	154	80	108	1 1/4"	116	530	DKLUIM025E	DKLUIM025F	DKLUIM025P
32	25	10	127	33	58	168	80	116	1 1/2"	124	725	DKLUIM032E	DKLUIM032F	DKLUIM032P
40	32	10	132	30	72	192	80	134	2"	140	811	DKLUIM040E	DKLUIM040F	DKLUIM040P
50	40	10	175	35	79	222	120	154	2 1/4"	160	1617	DKLUIM050E	DKLUIM050F	DKLUIM050P
63	50	10	200	46	98	266	120	184	2 3/4"	190	2353	DKLUIM063E	DKLUIM063F	DKLUIM063P

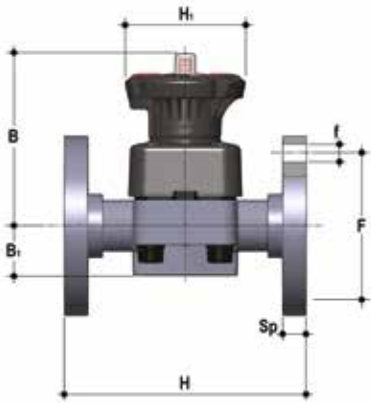

## DKOM

DIALOCK® diaphragm valve with flanged monolithic body, drilled PN10/16. Face to face according to EN 558-1

d	DN	PN	B	B <sub>1</sub>	F	f	H	H <sub>1</sub>	U	Sp	g	Code EPDM	Code FPM	Code PTFE
20	15	10	102	25	65	14	130	97	4	13.5	817	DKOM020E	DKOM020F	DKOM020P
25	20	10	105	30	75	14	150	97	4	13.5	850	DKOM025E	DKOM025F	DKOM025P
32	25	10	114	33	85	14	160	97	4	13.5	892	DKOM032E	DKOM032F	DKOM032P
40	32	10	119	30	100	18	180	97	4	14	1005	DKOM040E	DKOM040F	DKOM040P
50	40	10	149	35	110	18	200	126	4	16	1771	DKOM050E	DKOM050F	DKOM050P
63	50	10	172	46	125	18	230	157	4	16	2453	DKOM063E	DKOM063F	DKOM063P
75	65	10	172	46	145	18	290	157	4	21	2997	DKOM075E	DKOM075F	DKOM075P

DKLOM version available on request

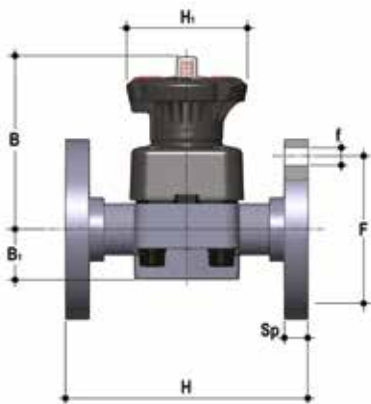

## DKOAM

DIALOCK® diaphragm valve with flanged monolithic body, drilled ANSI B16.5 cl. 150 #FF

d	DN	PN	B	B <sub>1</sub>	F	f	H	H <sub>1</sub>	U	Sp	g	Code EPDM	Code FPM	Code PTFE
1/2"	15	10	102	25	60.3	14	108	97	4	13.5	817	DKOAM012E	DKOAM012F	DKOAM012P
3/4"	20	10	105	30	70	15.7	120	97	4	13.5	850	DKOAM034E	DKOAM034F	DKOAM034P
1"	25	10	114	33	80	15.7	131	97	4	13.5	892	DKOAM100E	DKOAM100F	DKOAM100P
1" 1/4	32	10	119	30	89	15.7	162	97	4	14	1005	DKOAM114E	DKOAM114F	DKOAM114P
1" 1/2	40	10	149	35	99	15.7	180	126	4	16	1771	DKOAM112E	DKOAM112F	DKOAM112P
2"	50	10	172	46	121	19	210	157	4	16	2453	DKOAM200E	DKOAM200F	DKOAM200P
2" 1/2	65	10	172	46	140	19	250	157	4	21	2997	DKOAM0212E	DKOAM212F	DKOAM212P

DKLOAM version available on request

For spare parts related to installation prior to october 2017 please contact Fip Technical Support



# ACCESSORIES

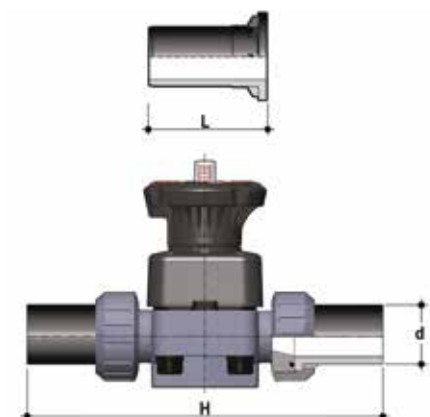

## Q/BBM-L

Long spigot PP-H end connectors for butt welding

d	DN	L	H	SDR	Code
20	15	95	280	11	QBBML11020
25	20	95	298	11	QBBML11025
32	25	95	306	11	QBBML11032
40	32	95	324	11	QBBML11040
50	40	95	344	11	QBBML11050
63	50	95	374	11	QBBML11063

## Q/BBM-C

Short spigot PP-H end connectors for butt welding

d	DN	L	H	SDR	Code
20	15	55	200	11	QBBMC11020
25	20	55	218	11	QBBMC11025
32	25	55	226	11	QBBMC11032
40	32	55	244	11	QBBMC11040
50	40	55	264	11	QBBMC11050
63	50	55	294	11	QBBMC11063

## Q/BBE-L

Long spigot PE100 end connectors for electrofusion or butt welding

d	DN	L	H	SDR	Code
20	15	95	280	11	QBBEL11020
25	20	95	298	11	QBBEL11025
32	25	95	306	11	QBBEL11032
40	32	95	324	11	QBBEL11040
50	40	95	344	11	QBBEL11050
63	50	95	374	11	QBBEL11063

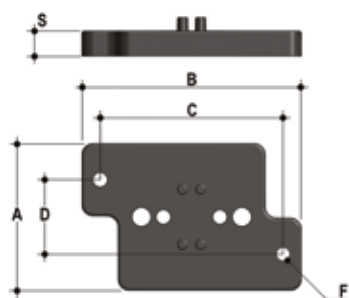

## PMDK

Wall mounting plate

d	DN	A	B	C	D	F	S	Code
20	15	65	97	81	33	5.5	11	PMDK1
25	20	65	97	81	33	5.5	11	PMDK1
32	25	65	97	81	33	5.5	11	PMDK1
40	32	65	97	81	33	5.5	11	PMDK1
50	40	65	144	130	33	6.5	11	PMDK2
63	50	65	144	130	33	6.5	11	PMDK2
75	65	65	144	130	33	6.5	11	PMDK2

# FASTENING AND SUPPORTING



All valves, whether manual or actuated, must be adequately supported in many applications.

The DK valve series is therefore provided with an integrated bracket that permits direct anchoring of the valve body without the need of other components.

For wall or panel installation, dedicated PMDK mounting plates which are available as accessories can be used. These plates should be fastened to the valve before wall installation.

PMDK plates also allow DK valve alignment with FIP ZIKM pipe clips.

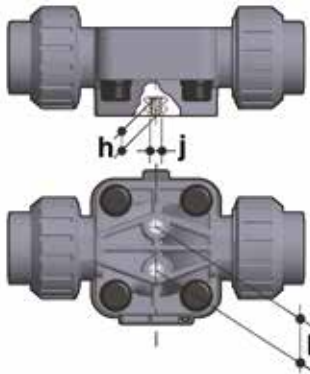

d	DN	h	l	J
20	15	10	25	M6
25	20	10	25	M6
32	25	10	25	M6
40	32	10	25	M6
50	40	13	44.5	M8
63	50	13	44.5	M8
75	65	13	44.5	M8

# CUSTOMISATION

The DIALOCK® DK DN 15÷65 valve can be customised using a customisation plate in white PVC.

The customisation plate (B), housed in the transparent protection cap (A), can be removed and, once overturned, used for indicating identification serial numbers or service indications on the valves such as, for example, the valve function in the system, the conveyed fluid, but also specific information for customer service, such as the customer name or installation date or location on the valves. The waterproof transparent protection cap with seal O-Ring protects the customisation plate against deterioration.

To access the customisation plate, make sure the handwheel is in the unlock position and proceed as follows:

- 1) Turn the transparent protection cap anti-clockwise to limit stop (fig. 1) and remove it by pulling it upwards and, if necessary, by inserting a screwdriver into the slot (C) to facilitate operation (fig. 2 ).
- 2) Remove the plate inside the transparent protection cap and customise it as required (fig. 3).
- 3) Re-assemble, making sure that the seal O-Ring of the transparent protection cap remains in its seating (fig. 4).

Fig. 1



Fig. 2



Fig. 3

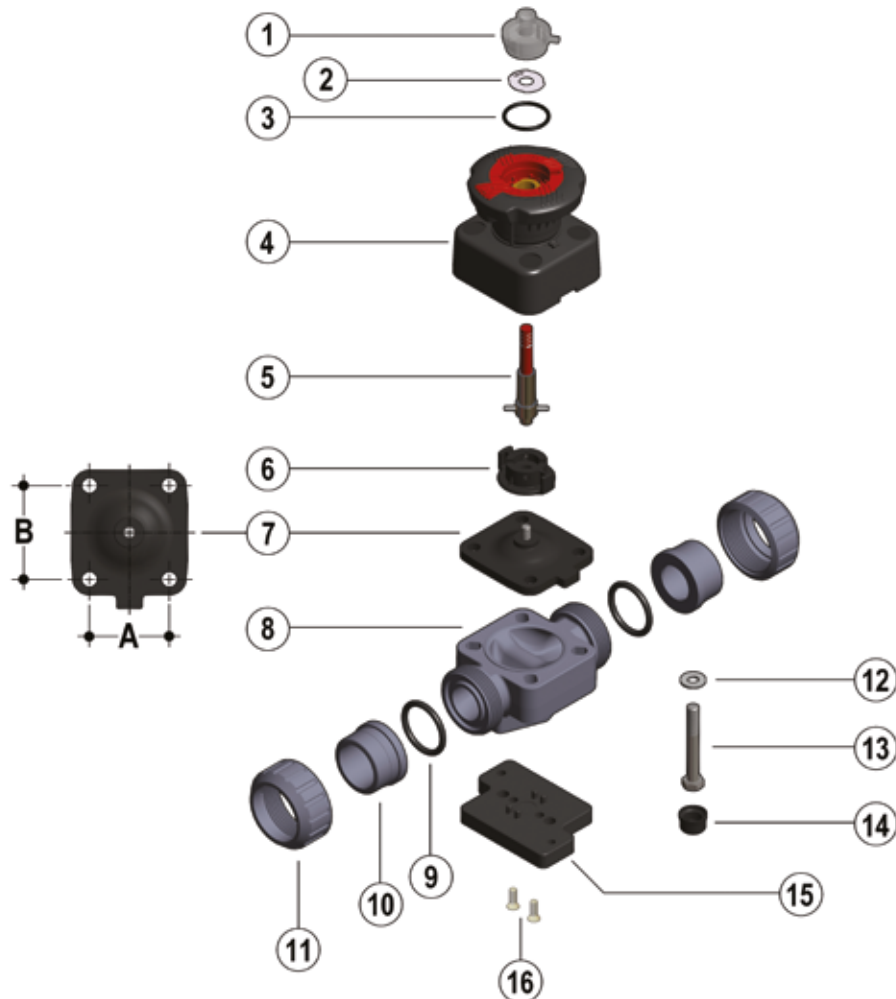

Fig. 4



# COMPONENTS

## EXPLODED VIEW DN 15÷65



DN	15	20	25	32	40	50	65
A	40	40	46	46	65	78	78
B	44	44	54	54	70	82	82

- 1 · Transparent protection cap (PVC - 1)\*
- 2 · Customisation plate (PVC-U - 1)
- 3 · O-Ring (EPDM - 1)
- 4 · Operating mechanism (PP-GR / PVDF - 1)
- 5 · Threaded stem - Indicator (STAINLESS steel - 1)

- 6 · Compressor (PA-GR IXEF® - 1)
- 7 · Diaphragm seal (EPDM, FPM, PTFE - 1)\*
- 8 · Valve body (PP-H - 1)\*
- 9 · Socket seal O-ring (EPDM-FPM - 2)\*
- 10 · End connector (PP-H - 2)\*
- 11 · Union nut (PP-H - 2)\*

- 12 · Washer (STAINLESS steel - 4)
- 13 · Bolt (STAINLESS steel - 4)
- 14 · Protection plug (PE - 4)
- 15 · Distance plate (PP-GR - 1)\*\*
- 16 · Screw (STAINLESS steel - 2)\*\*

\* Spare parts

\*\* Accessories

The material of the component and the quantity supplied are indicated in brackets

## DISMOUNTING

- 1) Isolate the valve from the line (release the pressure and empty the pipeline).
- 2) Unlock the handwheel if necessary by pushing it downwards (fig.5), and open the valve completely by turning it counter-clockwise.
- 3) Unscrew the union nuts (11) and extract the valve.
- 4) Remove the protection plugs (14) and remove the bolts (13) with the relative washers (12).
- 5) Separate the valve body (8) from the operating mechanism (4).
- 6) Rotate the handwheel clockwise until the threaded stem (5), the compressor (6) and the diaphragm (7) are released.
- 7) Unscrew the diaphragm (7) and remove the shutter (6).

## MOUNTING

- 1) Insert the compressor (6) onto the threaded stem (5), aligning it correctly with the stem pin.
- 2) Screw the diaphragm (7) onto the threaded stem (5).
- 3) Lubricate the threaded stem (5) and insert it into the operating mechanism (4), then turn the handwheel counter-clockwise until the stem is fully screwed in (5).  
Make sure that the compressor (6) and the diaphragm are properly aligned with the respective slots in the operating mechanism (4) (fig. 7).
- 4) Assemble the operating mechanism (4) on the body of the valve (8) and tighten the bolts (13) with the relative washers (12).
- 5) Tighten the bolts (13) evenly (diagonally) to the tightening torque suggested on the relative instruction sheet.
- 6) Replace the protection plugs (14).
- 7) Position the valve body between the end connectors (10) and tighten the union nuts (11), making sure that the socket seal O-rings (9) do not exit their seats.
- 8) If necessary, lock the handwheel by gripping it and pulling it upwards (fig.6).



**Note:** during assembly, it is advisable to lubricate the threaded stem  
Mineral oils are not recommended for this task as they react aggressively with EPDM rubber.

Fig. 5



Fig. 6



Fig. 7

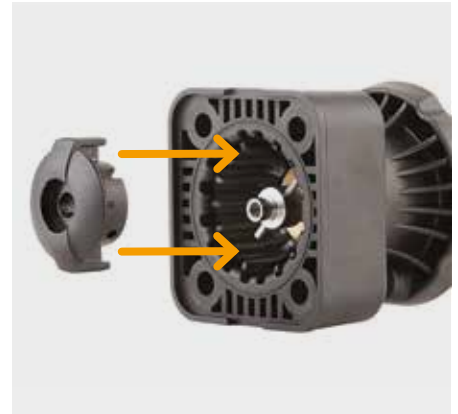

# INSTALLATION

Before proceeding with installation, please follow these instructions carefully: (instructions refer to versions with union ends). The valve can be installed in any position and in any direction.

- 1) Check that the pipes to be connected to the valve are aligned in order to avoid mechanical stress on the threaded joints.
- 2) Unscrew the union nuts (11) and insert them on the pipe segments.
- 3) Solvent weld or screw the end connectors (10) onto the pipe ends.
- 4) Position the valve between the end connectors making sure the socket seal O-Rings (9) do not exit the seats.
- 5) Fully tighten the union nuts (11).
- 6) If necessary, support the pipework with FIP pipe clips or by means of the carrier built into the valve itself (see paragraph "Fastening and supporting").

**⚠ Note:** Before putting the valve into service, check that the bolts on the valve body (13) are tightened correctly at the suggested torque.

Fig. 9



## LOCKING DEVICE



The DK valve is equipped with a DIALOCK® handwheel locking system that prevents the valve from being operated.

The system can be used simply by lifting the handwheel once it reaches the desired position (fig. 8).

To unlock, simply move the handwheel back to the previous position by pressing downwards (fig. 6).

When the system is in a locked position, it is also possible to install a lock to protect the system against tampering (fig. 9).

## STROKE LIMITER

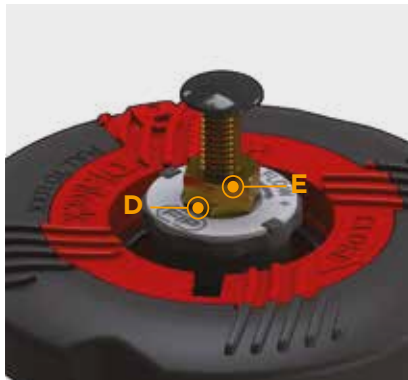

The DKL version of the diaphragm valve is equipped with a handwheel stroke control system which allows the minimum and maximum flows to be preset and preserves the diaphragm from excessive compression during closing operations.

The system allows the valve stroke to be modified using the two independent adjusting screws, which determine the mechanical limits of the valve during opening and closing. The valve is sold with the stroke limiters positioned so as not to limit the stroke both during closing and opening.

To access and set the adjusting screws, remove the transparent protection cap (A) as previously described (see chapter "Customisation").

### Travel stop adjustment. Minimum flow rate or valve closed.

- 1) Turn the handwheel clockwise until the desired minimum flow rate or the closed position is reached.
- 2) Fully screw the nut (D) to limit stop, and lock it in this position by tightening the locknut (E). If you want to exclude the stroke limiting function during closing, unscrew the nuts (D and E) completely. In this way, the valve will close completely.
- 3) Re-assemble the transparent protection cap making sure that the seal O-Ring remains in its seating.

### Stroke limiter adjustment. Maximum flow rate

- 1) Turn the handwheel counter-clockwise until the desired maximum flow rate is reached.
- 2) Turn the knob (F) counter-clockwise to limit stop. The plate shows the direction of rotation of the wheel to obtain a smaller or greater maximum flow rate. If it is not necessary to limit the opening stroke, turn the knob (F) clockwise several times. In this way, the valve will open completely.
- 3) Re-assemble the transparent protection cap making sure that the seal O-Ring remains in its seating.