

*Aliaxis*



**DKP/CP DN 25÷65**  
PVC-U / PP-H

Pneumatically actuated 2-way diaphragm valve

# DKP/CP DN 25÷65

The DKP/CP diaphragm valve is particularly suitable for shutting off and regulating abrasive or dirty fluids.

The new internal geometry of the body optimises fluid dynamic efficiency by increasing the flow rate and ensuring an optimum linearity of the flow adjustment curve. The DKP/CP is extremely compact and very light.

## PNEUMATICALLY ACTUATED 2-WAY DIAPHRAGM VALVE

- Connection system for solvent weld, threaded and flanged joints
- **Optimised fluid dynamic design:** maximum output flow rate thanks to the optimised efficiency of the fluid dynamics that characterise the new internal geometry of the body
- **Light and compact actuator piston in IXEF®** ideal for use in harsh environmental Conditions
- **High performance internal components:** piston in high mechanical strength IXEF® with main gasket and lubrication system
- **Modularity of the range:** only 3 actuators and diaphragms for 5 different valve sizes
- Bonnet fastening screws in stainless steel protected against the external environment by PE plugs. Absence of metal parts exposed to the external environment to prevent any risk of corrosion
- **CDSA** (Circular Diaphragm Sealing Angle) system that, thanks to the uniform distribution of shutter pressure on the diaphragm seal, offers the following advantages:
  - reduction in the tightening torque of the screws fixing the actuator to the valve body
  - reduced mechanical stress on all valve components (actuator, body and diaphragm)
  - easy to clean valve interior
  - low risk of the accumulation of deposits, contamination or damage to the diaphragm due to crystallisation

Technical specifications	
<b>Construction</b>	Pneumatically actuated diaphragm valve at optimized flow rate
<b>Size range</b>	DN 25 ÷ 65
<b>Nominal pressure</b>	PN 10 with water at 20 °C
<b>Temperature range</b>	<b>PVC-U:</b> 0 °C ÷ 60 °C <b>PP-H:</b> 0 °C ÷ 100 °C
<b>Coupling standards</b>	<b>Solvent welding:</b> EN ISO 1452, EN ISO 15493, EN ISO 15494, EN ISO 10931, BS 4346-1, DIN 8063, NF T54-028, ASTM D 2467, ASTM F 439. Can be coupled to pipes according to EN ISO 1452, EN ISO 15493, EN ISO 15494, EN ISO 10931, DIN 8062, NF T54-016, ASTM D 1785, ASTM F 441 <b>Thread:</b> ISO 228-1, DIN 2999, ASTM D 2464 <b>Flanging system:</b> ISO 7005-1, EN ISO 1452, EN ISO 15493, EN 1092-1, EN ISO 15494, EN ISO 10931, EN 558-1, DIN 2501, ANSI B16.5 Cl.150, JIS B2220
<b>Reference standards</b>	<b>Construction criteria:</b> EN ISO 16138, EN ISO 1452, EN ISO 15493, EN ISO 15494, EN ISO 10931 <b>Test methods and requirements:</b> ISO 9393 <b>Installation criteria:</b> DVS 2204, DVS 2221, DVS 2202-1, DVS 2201-1, DVS 2207-11, DVS 2207-15, DVS 2208-1, UNI 11242, UNI 11318
<b>Valve material</b>	PVC-U / PP-H (PVDF and PVC-C available on request)
<b>Diaphragm material</b>	EPDM, FPM, PTFE (on request NBR)
<b>Control options</b>	Pneumatic actuator

The compact and light piston actuator in IXEF® makes the DKP/CP the ideal choice for applications requiring very frequent valve operation and a long valve lifetime.

Technical specifications - pneumatic actuator	
<b>Construction</b>	Single-acting (NC-NO) and double-acting (DA) pneumatic piston actuator
<b>Actuator Material</b>	<b>Body and bonnet:</b> IXEF® (PA-GR)
<b>Control air pressure</b>	<b>Minimum:</b> according to the working pressure and operation of the actuator (see detailed graphs) <b>Maximum:</b> NC: 6 bar - NO: 5 bar - DA: 5 bar
<b>Power supply</b>	Dry or lubricated filtered compressed air. If using other fluids, contact the FIP service centre
<b>Control fluid temperature</b>	Max 40 °C
<b>Working temperature</b>	-20 °C ÷ 50 °C
<b>Accessories</b>	<ul style="list-style-type: none"> <li>• Optical position indicator</li> <li>• Stroke limiter with position indicator</li> <li>• Stroke limiter with position indicator and emergency manual override</li> <li>• Limit switch boxes</li> <li>• Electro-pneumatic positioner</li> <li>• Pilot solenoid valves 3-5/2 ways for direct or manifold mounting</li> <li>• Distance plate</li> </ul>

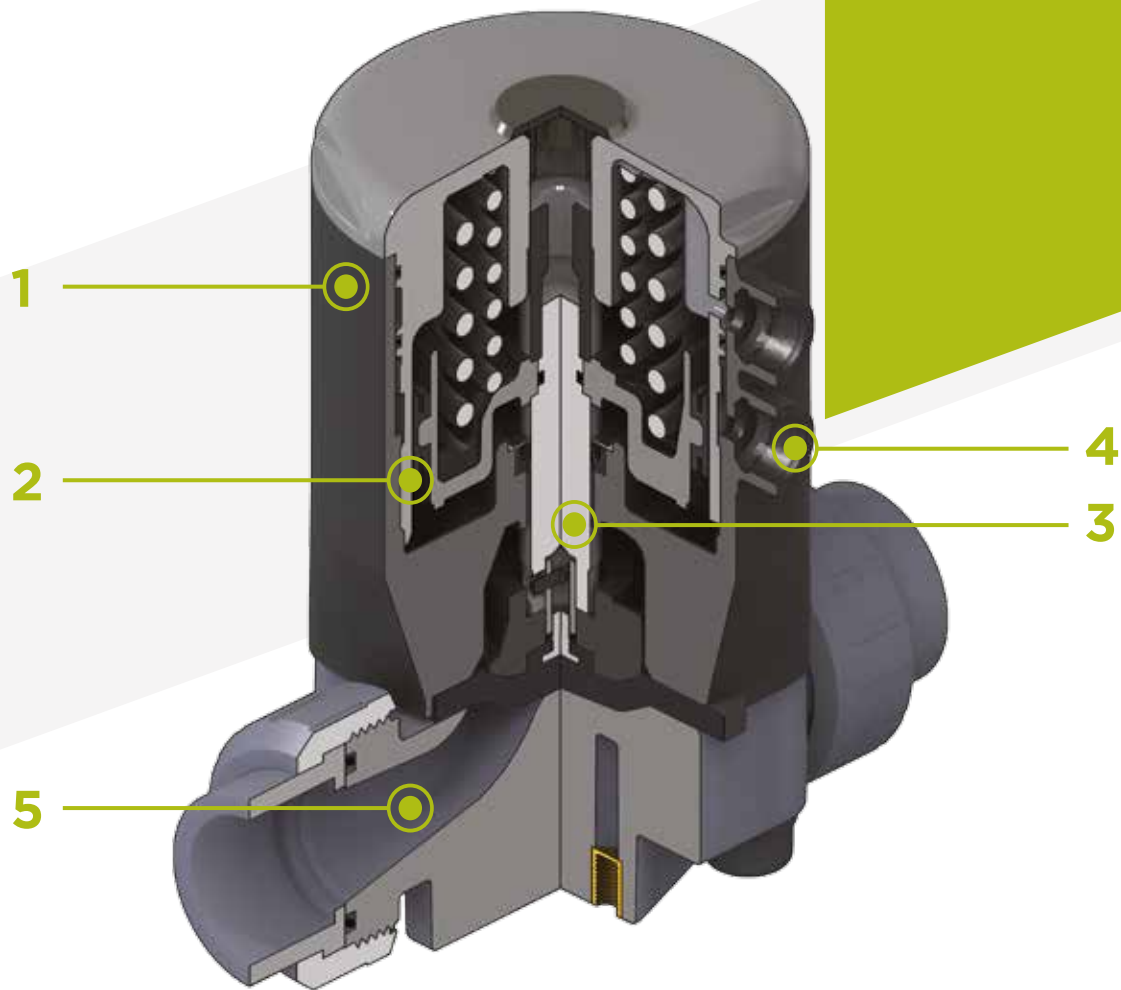

- 1** Light and compact actuator piston in IXEF® with a diaphragm perimeter containment system that ensures the perfect compression of the rubber without any lateral expansion
- 2** Piston in high strength IXEF® equipped with main gasket with lubrication system that allows up to 1 million valve operations to be performed without showing any signs of wear

**3** High strength stainless steel stem with floating pin connection between the actuator stem and diaphragm to prevent concentrated loads, improve the seal and extend its lifetime

**4** Easy to install, even in confined spaces: compressed air inlets with G 1/4" threaded metal connections, can be supplied in line with the piping

**5** New design of valve body interior. Substantially increased flow coefficient and reduced pressure drop. The degree of efficiency reached has also enabled the size and weight of the valve to be reduced. Adjustment linearity: the internal profiles of the valve also greatly improve its characteristic curve, resulting in extremely sensitive and precise adjustment along the entire stroke of the shutter.

# TECHNICAL DATA

## PRESSURE VARIATION ACCORDING TO TEMPERATURE

For water and harmless fluids to which the material is classified as CHEMICALLY RESISTANT. In other cases, a reduction of the nominal pressure PN is required (25 years with safety factor).

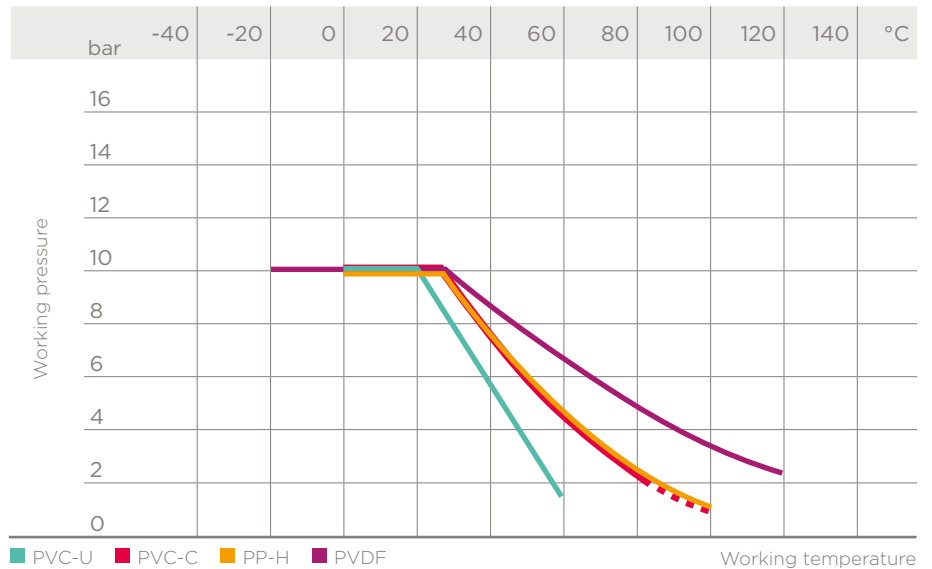

## PRESSURE DROP GRAPH

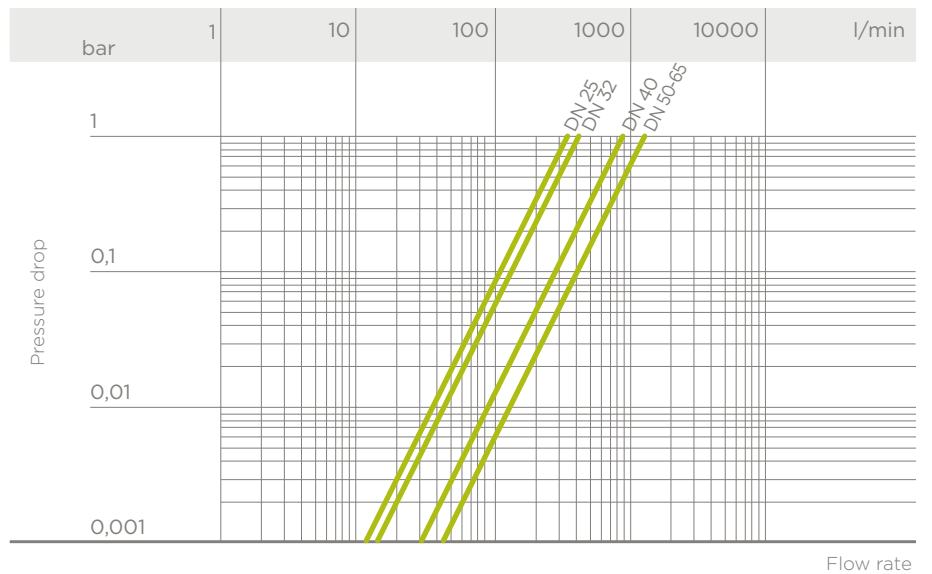

## K<sub>v</sub>100 FLOW COEFFICIENT

The K<sub>v</sub>100 flow coefficient is the Q flow of litres per minute of water at a temperature of 20°C that will generate Δp= 1 bar pressure drop at a certain valve position.

The K<sub>v</sub>100 values shown in the table are calculated with the valve completely open.

DN	25	32	40	50	65
K <sub>v</sub> 100 l/min	333	396	869	1359	1320

# TECHNICAL DATA

## RELATIVE FLOW COEFFICIENT GRAPH

The relative flow coefficient refers to the variation in the flow rate as a function of the valve opening stroke.

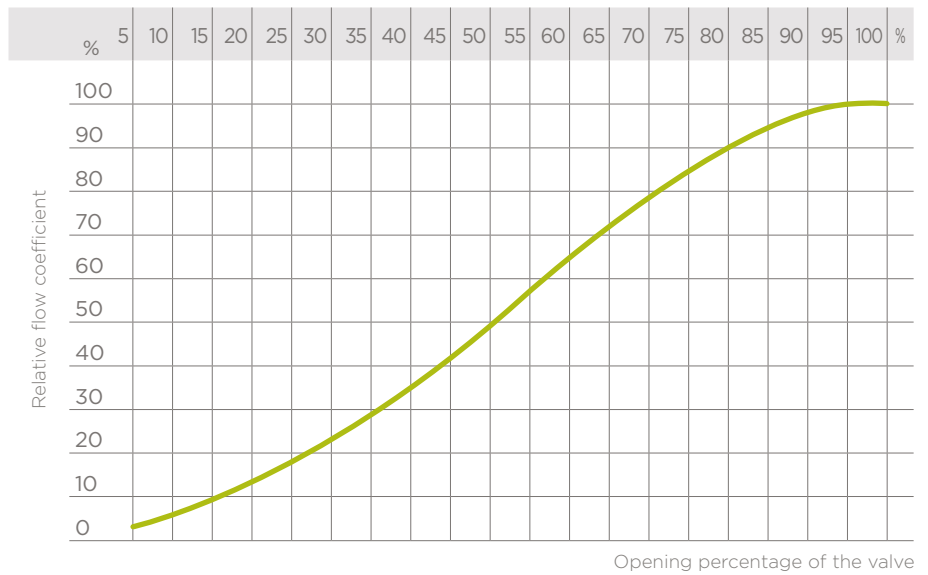

## CONTROL PRESSURE ACCORDING TO WORKING PRESSURE DKP/CP NC

Minimum control pressure according to working pressure with EPDM/FPM diaphragm

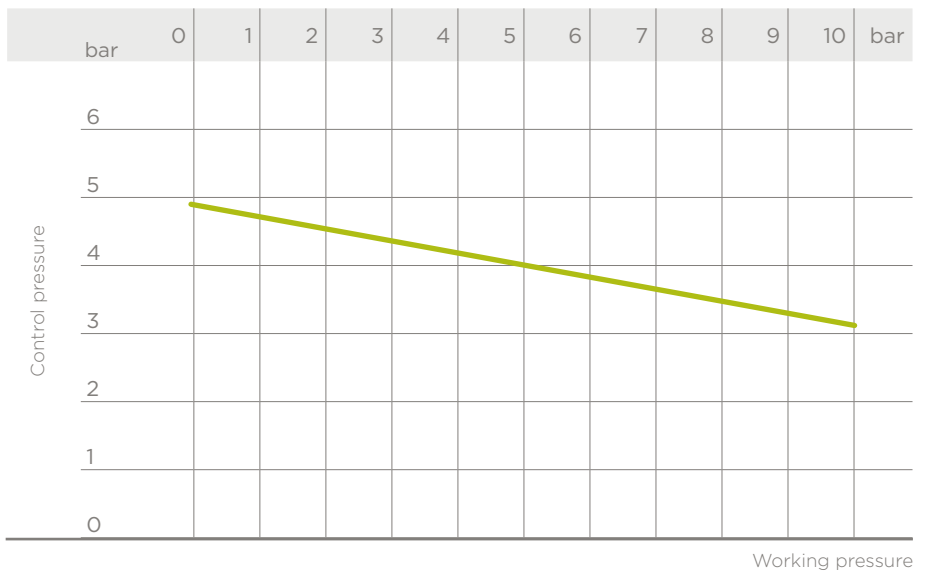

## CONTROL PRESSURE ACCORDING TO WORKING PRESSURE DKP/CP NO-DA

Minimum control pressure according to working pressure with EPDM/FPM diaphragm

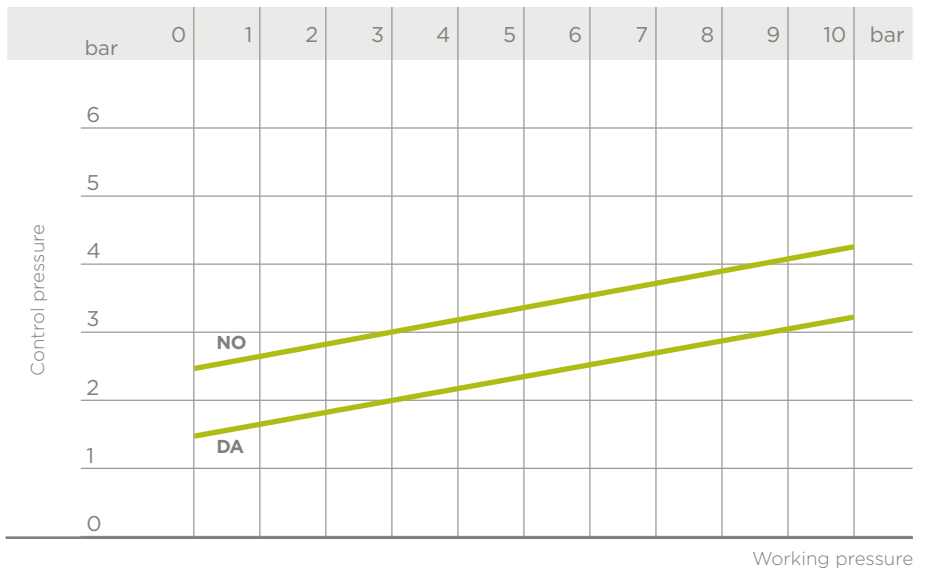

## FUNCTIONAL CHARACTERISTICS

	Double-acting (DA)	normally closed (NC)	normally open (NO)
Function type	double-acting	normally closed (NC)	normally open (NO)
Valve opening	air	air	spring
Valve closing	air	spring	air

## ACTUATOR CAPACITY

NI: Normal-liter

Volume at atmospheric pressure

DN	25	32	40	50	65
NC	0.17 NI	0.17 NI	0.31 NI	0.68 NI	0.68 NI
NO	0.19 NI	0.19 NI	0.33 NI	0.79 NI	0.79 NI
DA	0.20 NI	0.20 NI	0.34 NI	0.80 NI	0.80 NI

## COMPRESSED AIR CONNECTIONS

Function type	Normally closed (NC)	Normally open (NO)	Double-acting (DA)
Valve opening	Inlet B	-	Inlet B
Valve closing	-	Inlet A	Inlet A

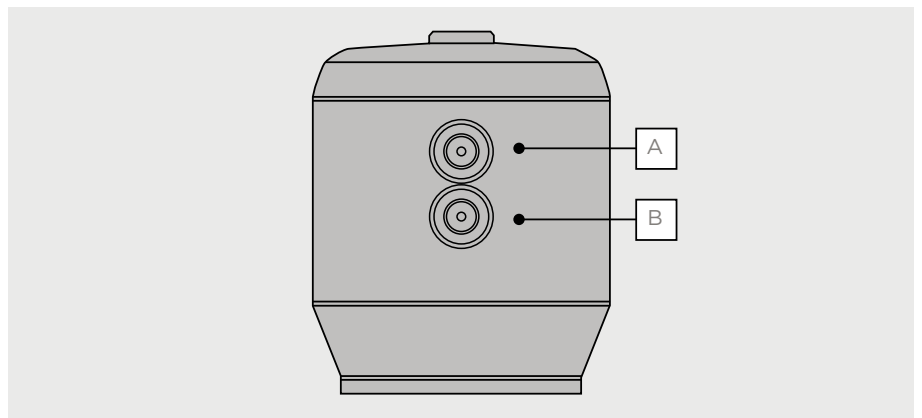

# DKP/CP RANGE DIMENSIONS



## DKPDV/CP DKPDM/CP

Pneumatically actuated diaphragm valve with male ends, metric series  
PVC-U, PP-H

d	DN	PN	B	B <sub>1</sub>	C	H	H <sub>1</sub>	L	Ra	NC	NO	<sup>g</sup> DA
32	25	10	140	33	90	154	95	22	1/4"	1344	1208	1098
40	32	10	142	30	92	174	95	26	1/4"	1388	1252	1142
50	40	10	169	35	101	194	114	31	1/4"	2444	1809	1699
63	50	10	211	46	140	224	144	38	1/4"	4354	3265	3068
75	65	10	211	46	140	284	144	44	1/4"	4484	3395	3198

Figures for PVC-U version PVC-C and PVDF versions available on request

## DKP/CP NC Codes

d	DN	DKPDV/CP PVC-U			DKPDM/CP PP-H		
		EPDM	FPM	PTFE	EPDM	FPM	PTFE
32	25	DKPDVNC032E	DKPDVNC032F	DKPDVNC032P	DKPDMNC032E	DKPDMNC032F	DKPDMNC032P
40	32	DKPDVNC040E	DKPDVNC040F	DKPDVNC040P	DKPDMNC040E	DKPDMNC040F	DKPDMNC040P
50	40	DKPDVNC050E	DKPDVNC050F	DKPDVNC050P	DKPDMNC050E	DKPDMNC050F	DKPDMNC050P
63	50	DKPDVNC063E	DKPDVNC063F	DKPDVNC063P	DKPDMNC063E	DKPDMNC063F	DKPDMNC063P
75	65	DKPDVNC075E	DKPDVNC075F	DKPDVNC075P	DKPDMNC075E	DKPDMNC075F	DKPDMNC075P

## DKP/CP NO Codes

d	DN	DKPDV/CP PVC-U			DKPDM/CP PP-H		
		EPDM	FPM	PTFE	EPDM	FPM	PTFE
32	25	DKPDVNO032E	DKPDVNO032F	DKPDVNO032P	DKPDMNO032E	DKPDMNO032F	DKPDMNO032P
40	32	DKPDVNO040E	DKPDVNO040F	DKPDVNO040P	DKPDMNO040E	DKPDMNO040F	DKPDMNO040P
50	40	DKPDVNO050E	DKPDVNO050F	DKPDVNO050P	DKPDMNO050E	DKPDMNO050F	DKPDMNO050P
63	50	DKPDVNO063E	DKPDVNO063F	DKPDVNO063P	DKPDMNO063E	DKPDMNO063F	DKPDMNO063P
75	65	DKPDVNO075E	DKPDVNO075F	DKPDVNO075P	DKPDMNO075E	DKPDMNO075F	DKPDMNO075P

## DKP/CP DA Codes

d	DN	DKPDV/CP PVC-U			DKPDM/CP PP-H		
		EPDM	FPM	PTFE	EPDM	FPM	PTFE
32	25	DKPDVDA032E	DKPDVDA032F	DKPDVDA032P	DKPMDA032E	DKPMDA032F	DKPMDA032P
40	32	DKPDVDA040E	DKPDVDA040F	DKPDVDA040P	DKPMDA040E	DKPMDA040F	DKPMDA040P
50	40	DKPDVDA050E	DKPDVDA050F	DKPDVDA050P	DKPMDA050E	DKPMDA050F	DKPMDA050P
63	50	DKPDVDA063E	DKPDVDA063F	DKPDVDA063P	DKPMDA063E	DKPMDA063F	DKPMDA063P
75	65	DKPDVDA075E	DKPDVDA075F	DKPDVDA075P	DKPMDA075E	DKPMDA075F	DKPMDA075P



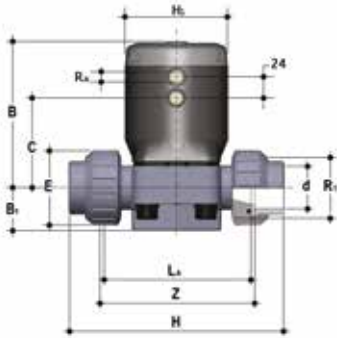

## DKPUIV/CP DKPUIM/CP

Pneumatically actuated diaphragm valve with female ends, metric series  
PVC-U, PP-H

d	DN	PN	B	B <sub>1</sub>	C	E	H	H <sub>1</sub>	La	R <sub>1</sub>	Z	NC	NO	<sup>g</sup> DA
32	25	10	140	33	90	58	168	95	116	1" 1/2	124	1452	1316	1206
40	32	10	142	30	92	72	192	95	134	2"	140	1578	1442	1332
50	40	10	169	35	101	79	222	114	154	2" 1/4	160	2656	2021	1911
63	50	10	211	46	140	98	266	144	184	2" 3/4	190	4750	3661	3464

Figures for PVC-U version PVC-C and PVDF versions available on request

## DKP/CP NC Codes

d	DN	DKPUIV/CP PVC-U			DKPUIM/CP PP-H		
		EPDM	FPM	PTFE	EPDM	FPM	PTFE
32	25	DKPUIVNC032E	DKPUIVNC032F	DKPUIVNC032P	DKPUIMNC032E	DKPUIMNC032F	DKPUIMNC032P
40	32	DKPUIVNC040E	DKPUIVNC040F	DKPUIVNC040P	DKPUIMNC040E	DKPUIMNC040F	DKPUIMNC040P
50	40	DKPUIVNC050E	DKPUIVNC050F	DKPUIVNC050P	DKPUIMNC050E	DKPUIMNC050F	DKPUIMNC050P
63	50	DKPUIVNC063E	DKPUIVNC063F	DKPUIVNC063P	DKPUIMNC063E	DKPUIMNC063F	DKPUIMNC063P

## DKP/CP NO Codes

d	DN	DKPUIV/CP PVC-U			DKPUIM/CP PP-H		
		EPDM	FPM	PTFE	EPDM	FPM	PTFE
32	25	DKPUIVNO032E	DKPUIVNO032F	DKPUIVNO032P	DKPUIMNO032E	DKPUIMNO032F	DKPUIMNO032P
40	32	DKPUIVNO040E	DKPUIVNO040F	DKPUIVNO040P	DKPUIMNO040E	DKPUIMNO040F	DKPUIMNO040P
50	40	DKPUIVNO050E	DKPUIVNO050F	DKPUIVNO050P	DKPUIMNO050E	DKPUIMNO050F	DKPUIMNO050P
63	50	DKPUIVNO063E	DKPUIVNO063F	DKPUIVNO063P	DKPUIMNO063E	DKPUIMNO063F	DKPUIMNO063P

## DKP/CP DA Codes

d	DN	DKPUIV/CP PVC-U			DKPUIM/CP PP-H		
		EPDM	FPM	PTFE	EPDM	FPM	PTFE
32	25	DKPUIVDA032E	DKPUIVDA032F	DKPUIVDA032P	DKPUIMDA032E	DKPUIMDA032F	DKPUIMDA032P
40	32	DKPUIVDA040E	DKPUIVDA040F	DKPUIVDA040P	DKPUIMDA040E	DKPUIMDA040F	DKPUIMDA040P
50	40	DKPUIVDA050E	DKPUIVDA050F	DKPUIVDA050P	DKPUIMDA050E	DKPUIMDA050F	DKPUIMDA050P
63	50	DKPUIVDA063E	DKPUIVDA063F	DKPUIVDA063P	DKPUIMDA063E	DKPUIMDA063F	DKPUIMDA063P

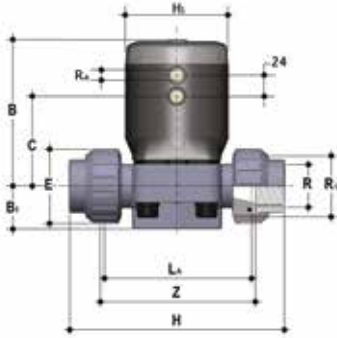

## DKPUFV/CP

Pneumatically actuated diaphragm valve with BSP threaded female union ends, PVC-U series

d	DN	PN	B	B <sub>1</sub>	C	E	H	H <sub>1</sub>	La	R <sub>1</sub>	Ra	Z	NC	NO	<sup>g</sup> DA
1"	25	10	140	33	90	58	165	95	116	1" 1/2	1/4"	127	1452	1316	1206
1" 1/4	32	10	142	30	92	72	188	95	134	2"	1/4"	145	1578	1442	1332
1" 1/2	40	10	169	35	101	79	208	114	154	2" 1/4	1/4"	165	2656	2021	1911
2"	50	10	211	46	140	98	246	144	184	2" 3/4	1/4"	195	4750	3661	3464

PVC-C versions available on request

## DKP/CP NC Codes

d	DN	DKPUFV/CP PVC-U	
		EPDM	FPM
1"	25	DKPUFVNC100E	DKPUFVNC100F
1" 1/4	32	DKPUFVNC114E	DKPUFVNC114F
1" 1/2	40	DKPUFVNC112E	DKPUFVNC112F
2"	50	DKPUFVNC200E	DKPUFVNC200F

## DKP/CP NO Codes

d	DN	DKPUFV/CP PVC-U	
		EPDM	FPM
1"	25	DKPUFVNO100E	DKPUFVNO100F
1" 1/4	32	DKPUFVNO114E	DKPUFVNO114F
1" 1/2	40	DKPUFVNO112E	DKPUFVNO112F
2"	50	DKPUFVNO200E	DKPUFVNO200F

## DKP/CP DA Codes

d	DN	DKPUFV/CP PVC-U	
		EPDM	FPM
1"	25	DKPUFVDA100E	DKPUFVDA100F
1" 1/4	32	DKPUFVDA114E	DKPUFVDA114F
1" 1/2	40	DKPUFVDA112E	DKPUFVDA112F
2"	50	DKPUFVDA200E	DKPUFVDA200F

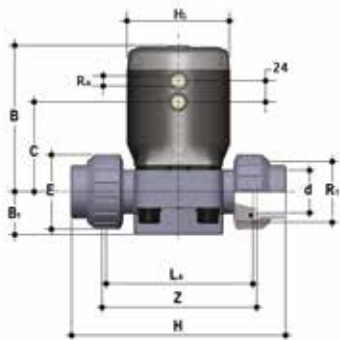

## DKPUAV/CP

Pneumatically actuated diaphragm valve with female union ends for solvent welding, ASTM PVC-U series

d	DN	PN	B	B <sub>1</sub>	C	E	H	H <sub>1</sub>	La	R <sub>1</sub>	Ra	Z	NC	NO	<sup>g</sup> DA
1"	25	10	140	33	90	58	180	95	116	1" 1/2	1/4"	122	1452	1316	1206
1" 1/4	32	10	142	30	92	72	208	95	134	2"	1/4"	144	1578	1442	1332
1" 1/2	40	10	169	35	101	79	234	114	154	2" 1/4	1/4"	164	2656	2021	1911
2"	50	10	211	46	140	98	272	144	184	2" 3/4	1/4"	195	4750	3661	3464

Figures for PVC-U version PP-H, PVC-C and PVDF versions available on request

## DKP/CP NC Codes

d	DN			DKPUAV/CP PVC-U	
		EPDM	FPM	PTFE	
1"	25	DKPUAVNC100E	DKPUAVNC100F	DKPUAVNC100P	
1" 1/4	32	DKPUAVNC114E	DKPUAVNC114F	DKPUAVNC114P	
1" 1/2	40	DKPUAVNC112E	DKPUAVNC112F	DKPUAVNC112P	
2"	50	DKPUAVNC200E	DKPUAVNC200F	DKPUAVNC200P	

## DKP/CP NO Codes

d	DN			DKPUAV/CP PVC-U	
		EPDM	FPM	PTFE	
1"	25	DKPUAVNO100E	DKPUAVNO100F	DKPUAVNO100P	
1" 1/4	32	DKPUAVNO114E	DKPUAVNO114F	DKPUAVNO114P	
1" 1/2	40	DKPUAVNO112E	DKPUAVNO112F	DKPUAVNO112P	
2"	50	DKPUAVNO200E	DKPUAVNO200F	DKPUAVNO200P	

## DKP/CP DA Codes

d	DN			DKPUAV/CP PVC-U	
		EPDM	FPM	PTFE	
1"	25	DKPUAVDA100E	DKPUAVDA100F	DKPUAVDA100P	
1" 1/4	32	DKPUAVDA114E	DKPUAVDA114F	DKPUAVDA114P	
1" 1/2	40	DKPUAVDA112E	DKPUAVDA112F	DKPUAVDA112P	
2"	50	DKPUAVDA200E	DKPUAVDA200F	DKPUAVDA200P	

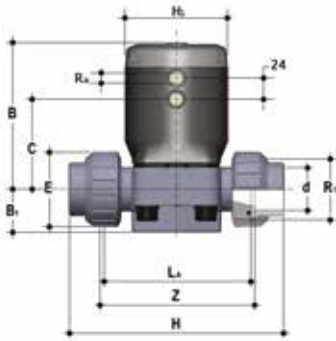

## DKPULV/CP

Pneumatically actuated diaphragm valve with female union ends for solvent welding, BS PVC-U series

d	DN	PN	B	B <sub>1</sub>	C	E	H	H <sub>1</sub>	La	R <sub>1</sub>	Ra	Z	NC	NO	<sup>g</sup> DA
1"	25	10	140	33	90	58	166	95	116	1" 1/2	1/4"	121	1452	1316	1206
1" 1/4	32	10	142	30	92	72	194	95	134	2"	1/4"	142	1578	1442	1332
1" 1/2	40	10	169	35	101	79	222	114	154	2" 1/4	1/4"	162	2656	2021	1911
2"	50	10	211	46	140	98	266	144	184	2" 3/4	1/4"	194	4750	3661	3464

## DKP/CP NC Codes

d	DN	DKPULV/CP PVC-U	
		EPDM	FPM
1"	25	DKPULVNC100E	DKPULVNC100F
1" 1/4	32	DKPULVNC114E	DKPULVNC114F
1" 1/2	40	DKPULVNC112E	DKPULVNC112F
2"	50	DKPULVNC200E	DKPULVNC200F

## DKP/CP NO Codes

d	DN	DKPULV/CP PVC-U	
		EPDM	FPM
1"	25	DKPULVNO100E	DKPULVNO100F
1" 1/4	32	DKPULVNO114E	DKPULVNO114F
1" 1/2	40	DKPULVNO112E	DKPULVNO112F
2"	50	DKPULVNO200E	DKPULVNO200F

## DKP/CP DA Codes

d	DN	DKPULV/CP PVC-U	
		EPDM	FPM
1"	25	DKPULVDA100E	DKPULVDA100F
1" 1/4	32	DKPULVDA114E	DKPULVDA114F
1" 1/2	40	DKPULVDA112E	DKPULVDA112F
2"	50	DKPULVDA200E	DKPULVDA200F

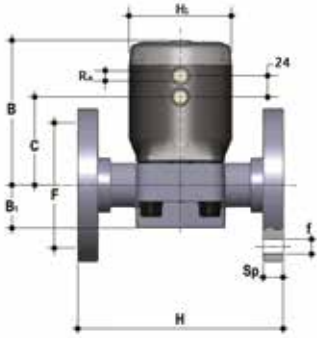

## DKPOV/CP DKPOM/CP

Pneumatically actuated diaphragm valve with monolithic flanged body, drilled PN10/16.  
Face to face according to EN 558-1 PVC-U, PP-H

d	DN	PN	B	B <sub>1</sub>	C	F	Øf	H	H <sub>1</sub>	Ra	U	Sp	NC	NO	g DA
32	25	10	140	33	90	85	14	160	95	1/4"	4	14	1634	1498	1388
40	32	10	142	30	92	100	18	180	95	1/4"	4	14	1848	1712	1602
50	40	10	169	35	101	110	18	200	114	1/4"	4	16	3019	2384	2274
63	50	10	211	46	140	125	18	230	144	1/4"	4	16	5124	4035	3838
75	65	10	211	46	140	145	18	290	144	1/4"	4	21	5584	4495	4298

Figures for PVC-U version PVC-C and PVDF versions available on request

## DKP/CP NC Codes

d	DN	DKPOV/CP PVC-U						DKPOM/CP PP-H	
		EPDM	FPM	PTFE	EPDM	FPM	PTFE		
32	25	DKPOVNC032E	DKPOVNC032F	DKPOVNC032P	DKPOMNC032E	DKPOMNC032F	DKPOMNC032P		
40	32	DKPOVNC040E	DKPOVNC040F	DKPOVNC040P	DKPOMNC040E	DKPOMNC040F	DKPOMNC040P		
50	40	DKPOVNC050E	DKPOVNC050F	DKPOVNC050P	DKPOMNC050E	DKPOMNC050F	DKPOMNC050P		
63	50	DKPOVNC063E	DKPOVNC063F	DKPOVNC063P	DKPOMNC063E	DKPOMNC063F	DKPOMNC063P		
75	65	DKPOVNC075E	DKPOVNC075F	DKPOVNC075P	DKPOMNC075E	DKPOMNC075F	DKPOMNC075P		

## DKP/CP NO Codes

d	DN	DKPOV/CP PVC-U						DKPOM/CP PP-H	
		EPDM	FPM	PTFE	EPDM	FPM	PTFE		
32	25	DKPOVNO032E	DKPOVNO032F	DKPOVNO032P	DKPOMNO032E	DKPOMNO032F	DKPOMNO032P		
40	32	DKPOVNO040E	DKPOVNO040F	DKPOVNO040P	DKPOMNO040E	DKPOMNO040F	DKPOMNO040P		
50	40	DKPOVNO050E	DKPOVNO050F	DKPOVNO050P	DKPOMNO050E	DKPOMNO050F	DKPOMNO050P		
63	50	DKPOVNO063E	DKPOVNO063F	DKPOVNO063P	DKPOMNO063E	DKPOMNO063F	DKPOMNO063P		
75	65	DKPOVNO075E	DKPOVNO075F	DKPOVNO075P	DKPOMNO075E	DKPOMNO075F	DKPOMNO075P		

## DKP/CP DA Codes

d	DN	DKPOV/CP PVC-U						DKPOM/CP PP-H	
		EPDM	FPM	PTFE	EPDM	FPM	PTFE		
32	25	DKPOVDA032E	DKPOVDA032F	DKPOVDA032P	DKPOMDA032E	DKPOMDA032F	DKPOMDA032P		
40	32	DKPOVDA040E	DKPOVDA040F	DKPOVDA040P	DKPOMDA040E	DKPOMDA040F	DKPOMDA040P		
50	40	DKPOVDA050E	DKPOVDA050F	DKPOVDA050P	DKPOMDA050E	DKPOMDA050F	DKPOMDA050P		
63	50	DKPOVDA063E	DKPOVDA063F	DKPOVDA063P	DKPOMDA063E	DKPOMDA063F	DKPOMDA063P		
75	65	DKPOVDA075E	DKPOVDA075F	DKPOVDA075P	DKPOMDA075E	DKPOMDA075F	DKPOMDA075P		

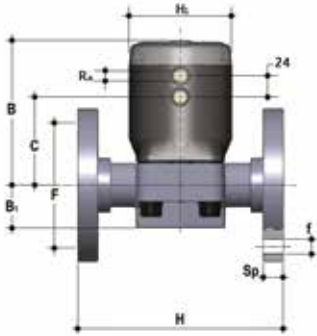

## DKPOAV/CP DKPOAM/CP

Pneumatically actuated diaphragm valve with monolithic flanged body, drilled ANSI B16.5 cl. 150 #FF. Face to face according to EN 558-1 PVC-U, PP-H

d	DN	PN	B	B <sub>1</sub>	C	F	Øf	H	H <sub>1</sub>	Ra	U	Sp	NC	NO	g DA
1"	25	10	140	33	90	79,4	15,9	131	95	1/4"	4	14	1634	1498	1388
1" 1/4	32	10	142	30	92	88,9	15,9	162	95	1/4"	4	14	1848	1712	1602
1" 1/2	40	10	169	35	101	98,4	15,9	180	114	1/4"	4	16	3019	2384	2274
2"	50	10	211	46	140	120,7	19,1	210	144	1/4"	4	16	5124	4035	3838
2" 1/2	65	10	211	46	140	139,7	19,1	250	144	1/4"	4	21	5584	4495	4298

Figures for PVC-U version PVC-C and PVDF versions available on request  
For spare parts related to installation prior to october 2017 please contact FIP Technical Support

## DKP/CP NC Codes

d	DN	DKPOAV/CP PVC-U						DKPOAM/CP PP-H		
		EPDM	FPM	PTFE	EPDM	FPM	PTFE			
1"	25	DKPOAVNC100E	DKPOAVNC100F	DKPOAVNC100P	DKPOAMNC100E	DKPOAMNC100F	DKPOAMNC100P			
1" 1/4	32	DKPOAVNC114E	DKPOAVNC114F	DKPOAVNC114P	DKPOAMNC114E	DKPOAMNC114F	DKPOAMNC114P			
1" 1/2	40	DKPOAVNC112E	DKPOAVNC112F	DKPOAVNC112P	DKPOAMNC112E	DKPOAMNC112F	DKPOAMNC112P			
2"	50	DKPOAVNC200E	DKPOAVNC200F	DKPOAVNC200P	DKPOAMNC200E	DKPOAMNC200F	DKPOAMNC200P			
2" 1/2	65	DKPOAVNC212E	DKPOAVNC212F	DKPOAVNC212P	DKPOAMNC212E	DKPOAMNC212F	DKPOAMNC212P			

## DKP/CP NO Codes

d	DN	DKPOAV/CP PVC-U						DKPOAM/CP PP-H		
		EPDM	FPM	PTFE	EPDM	FPM	PTFE			
1"	25	DKPOAVNO100E	DKPOAVNO100F	DKPOAVNO100P	DKPOAMNO100E	DKPOAMNO100F	DKPOAMNO100P			
1" 1/4	32	DKPOAVNO114E	DKPOAVNO114F	DKPOAVNO114P	DKPOAMNO114E	DKPOAMNO114F	DKPOAMNO114P			
1" 1/2	40	DKPOAVNO112E	DKPOAVNO112F	DKPOAVNO112P	DKPOAMNO112E	DKPOAMNO112F	DKPOAMNO112P			
2"	50	DKPOAVNO200E	DKPOAVNO200F	DKPOAVNO200P	DKPOAMNO200E	DKPOAMNO200F	DKPOAMNO200P			
2" 1/2	65	DKPOAVNO212E	DKPOAVNO212F	DKPOAVNO212P	DKPOAMNO212E	DKPOAMNO212F	DKPOAMNO212P			

## DKP/CP DA Codes

d	DN	DKPOAV/CP PVC-U						DKPOAM/CP PP-H		
		EPDM	FPM	PTFE	EPDM	FPM	PTFE			
1"	25	DKPOAVDA100E	DKPOAVDA100F	DKPOAVDA100P	DKPOAMDA100E	DKPOAMDA100F	DKPOAMDA100P			
1" 1/4	32	DKPOAVDA114E	DKPOAVDA114F	DKPOAVDA114P	DKPOAMDA114E	DKPOAMDA114F	DKPOAMDA114P			
1" 1/2	40	DKPOAVDA112E	DKPOAVDA112F	DKPOAVDA112P	DKPOAMDA112E	DKPOAMDA112F	DKPOAMDA112P			
2"	50	DKPOAVDA200E	DKPOAVDA200F	DKPOAVDA200P	DKPOAMDA200E	DKPOAMDA200F	DKPOAMDA200P			
2" 1/2	65	DKPOAVDA212E	DKPOAVDA212F	DKPOAVDA212P	DKPOAMDA212E	DKPOAMDA212F	DKPOAMDA212P			

# ACCESSORIES

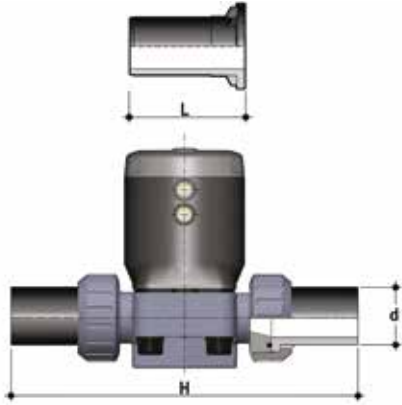

## Q/BBE-L

Long spigot PE100 end connectors for electrofusion or butt welding

d	DN	L	H	SDR	Code
32	25	95	306	11	QBBEL11032
40	32	95	324	11	QBBEL11040
50	40	95	344	11	QBBEL11050
63	50	95	374	11	QBBEL11063

## Q/BBM-L

Long spigot PP-H end connectors for butt welding

d	DN	L	H	SDR	Code
32	25	95	306	11	QBBML11032
40	32	95	324	11	QBBML11040
50	40	95	344	11	QBBML11050
63	50	95	374	11	QBBML11063

## Q/BBM-C

Short spigot PP-H end connectors for butt welding

d	DN	L	H	SDR	Code
32	25	55	226	11	QBBMC11032
40	32	55	244	11	QBBMC11040
50	40	55	264	11	QBBMC11050
63	50	55	294	11	QBBMC11063

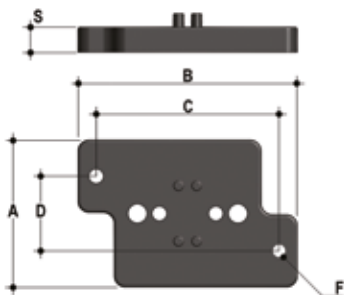

## PMDK

Wall mounting plate

d	DN	A	B	C	D	F	S	Code
32	25	65	97	81	33	5.5	11	PMDK1
40	32	65	97	81	33	5.5	11	PMDK2
50	40	65	144	130	33	6.5	11	PMDK2
63	50	65	144	130	33	6.5	11	PMDK2
75	65	65	144	130	33	6.5	11	PMDK2

# FASTENING AND SUPPORTING



All valves, whether manual or actuated, must be adequately supported in many applications.

The DK valve series is therefore provided with an integrated bracket that permits direct anchoring of the valve body without the need of other components.

For wall installation, dedicated PMDK mounting plates which are available as accessories can be used. These plates should be fastened to the valve before wall installation.

The PMDK plate also allows the DK valve to be aligned with FIP ZIKM pipe clips.

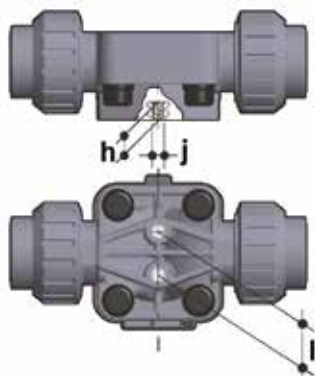

d	DN	h	l	j
32	25	10	25	M6
40	32	10	25	M6
50	40	13	44,5	M8
63	50	13	44,5	M8
75	65	13	44,5	M8



# COMPONENTS

## EXPLODED VIEW DN 25÷65

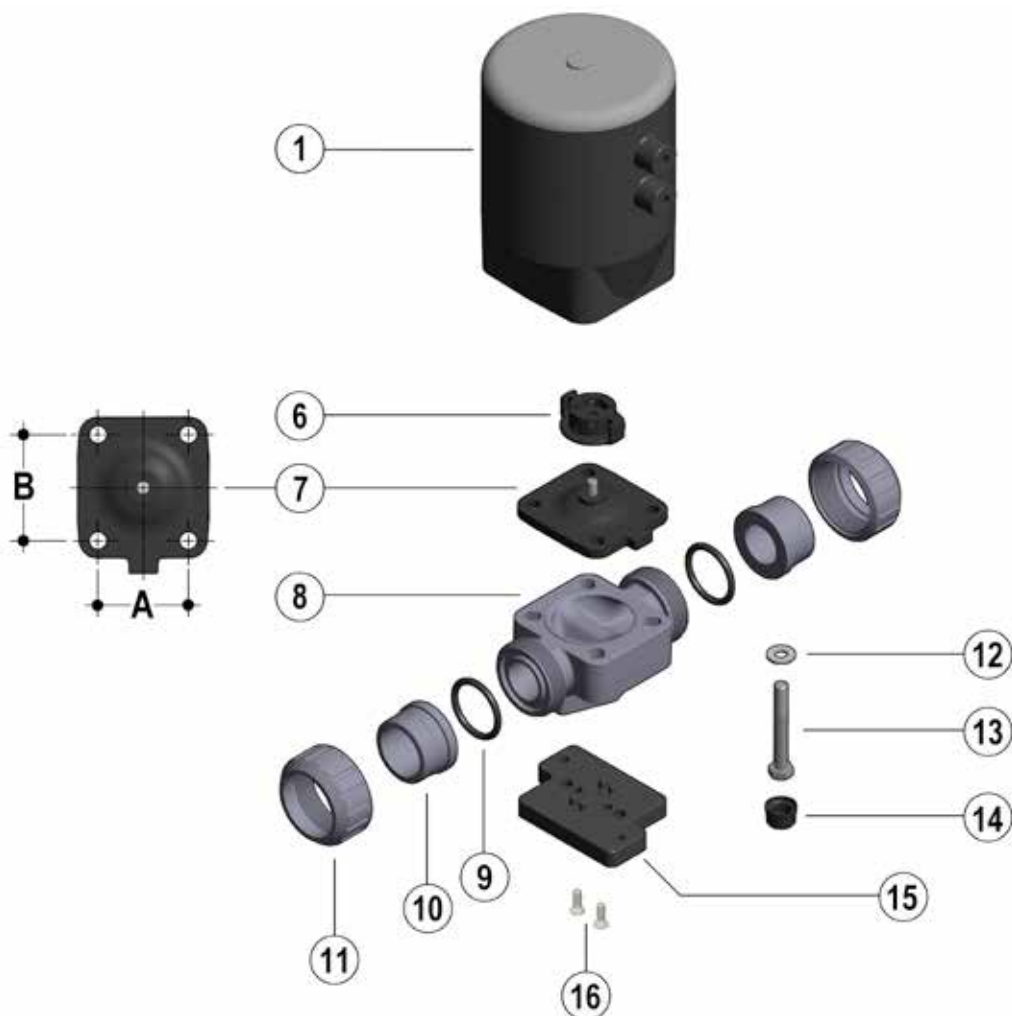

DN	25	32	40	50	65
A	46	46	65	78	78
B	54	54	70	82	82

**1.** Actuator (IXEF® - 1)\*

**6.** Compressor (IXEF® - 1)

**7.** Diaphragm seal (EPDM, FPM, PTFE - 1)\*

**8.** Valve body (PVC-U, PPH - 1)\*

**9.** Socket seal O-ring (EPDM-FPM - 2)\*

**10.** End connector (PVC-U, PPH - 2)\*

**11.** Union nut (PVC-U, PPH - 2)\*

**12.** Washer (Stainless steel - 4)

**13.** Bolt (Stainless steel - 4)

**14.** Protection plug (PE - 4)

**15.** Distance plate (PP-GR - 1)\*\*

**16.** Screw (Stainless steel - 2)\*\*

\* Spare parts

\*\* Accessories

The material of the component and the quantity supplied are indicated between brackets

## DISASSEMBLY

- 1) Isolate the valve from the line (release the pressure and empty the pipeline).
- 2) Open the valve with compressed air (NC-DA) to drain any residual liquid from the valve.
- 3) Disconnect the valve from the pneumatic and electrical connections.
- 4) Fully unscrew the union nuts (11) and extract the valve sideways.
- 5) Remove the protection plugs (14) and bolts (13) with the relative washers (12). This operation will be made easier if the actuator is pressurised (NC).
- 6) Separate the valve body (8) from the actuator (1).
- 7) Unscrew the diaphragm (7) and remove the compressor (6). This operation will be made easier if the actuator is not pressurised (NC).

## ASSEMBLY

- 1) Insert the compressor (6) on the actuator stem (1) aligning it correctly in its housing (fig. 1).
- 2) Screw the diaphragm (7) onto the stem, aligning it correctly with its housing on the actuator.
- 3) Fit the actuator (1) on the valve body (8) and tighten the bolts (13) with the relative washers (12). This operation will be made easier if the actuator is pressurised (NC).
- 4) Tighten the bolts (13) evenly (diagonally) to the tightening torque suggested on the relative instruction sheet.
- 5) Replace the protection plugs (14)
- 6) Position the valve between the end connectors (10) and tighten the union nuts (11), making sure that the socket seal O-rings (9) do not exit their seats.
- 7) Reconnect the valve to the pneumatic and electrical connections



**Note:** All operations on equipment under pressure or containing compressed springs must be carried out under safe conditions for the operator.

Fig. 1

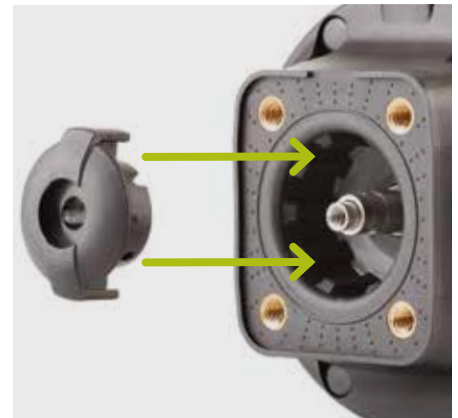

Fig. 2



## INSTALLATION

Before proceeding with installation, please follow these instructions carefully: (these instructions refer to union ends versions). The valve can be installed in any position and in any direction.

- 1) Check that the pipes to be connected to the valve are aligned in order to avoid mechanical stress on the threaded joints.
- 2) Unscrew the union nuts (11) and insert them on the pipe segments.
- 3) Solvent weld or screw the end connectors (10) onto the pipe ends.
- 4) Position the valve body between the end connectors, making sure that the socket seal O-rings (9) do not exit their seats.
- 5) Fully tighten the union nuts (11).
- 6) If necessary, support the pipework with FIP pipe clips or by means of the carrier built into the valve itself (see paragraph "Fastening and supporting").
- 7) Connect the compressed air as indicated in paragraph "Compressed air connections". For valves with electric accessories, refer to the specific technical manual supplied with the accessory.

When installing in confined spaces, a version is available with the connections oriented in line with the piping (fig. 2).



**Note:** before putting the valve into service, check that the bolts on the valve body (8) are tightened correctly at the suggested torque.



*Aliaxis*

**FIP - Formatura Iniezione Polimeri**

Loc. Pian di Parata, 16015 Casella Genova Italy

Tel. +39 010 9621.1

Fax +39 010 9621.209

info.fip@aliaxis.com

[www.fipnet.com](http://www.fipnet.com)



Code LEVAUTO 11/2017 Rev-02